



**EV charging and PV storage monitoring solutions**

**Controls**

# Climate-neutral

## From carbon to renewable energy

### ■ What is carbon neutrality?

Consist in achieving a balance between emissions and carbon absorption. When carbon dioxide is removed from the atmosphere it is called carbon immobilization.

To achieve this goal, the emission of greenhouse gases (GHG) will have to be offset by the absorption of carbon emissions.

Another way to reduce emissions is to offset emissions in one sector by reducing them in another. This can be done by investing in renewable energy and clean technologies.

To illustrate emission reduction in practice, the Regional Greenhouse Gas Initiative (RGGI), initiated in 2009, stands as the first U.S. cap-and-trade program targeting the power sector's carbon dioxide emissions. Involving eleven states, including Connecticut, Delaware, and New York, RGGI caps emissions and facilitates their trading among power plants.

This approach has halved emissions from their 2005 peak, generating nearly \$3 billion in economic benefits and setting a target to cut emissions 30% below 2020 levels by 2030.

### ■ US will require actions on all economical sectors :



**ENERGY**  
Decarbonise the energy sector.



**BUILDINGS**  
Renovate buildings, to help people cut their energy bills and energy use.



**INDUSTRY**  
Support industry to innovate and to become global leaders in the green economy.



**MOBILITY**  
Roll out cleaner, cheaper and healthier forms of private and public transportation.



## ■ Setting all actions for the next target

Making the USA climate-neutral will be good for people, the planet and the economy

- BECOME climate-neutral
- PROTECT life by cutting pollution
- HELP companies become world leaders in clean products and technologies

Focus on

- Smart networks and batteries
- Energy storage
- Carbon-neutral transformation of energy industries
- Circular economy



# EV charge

## Green mobility

### ■ Need a green planet for all

Carbon dioxide continues to rise every month. Greenhouse gas levels are so high because humans have released them into the air by burning fossil fuels. The gases absorb solar energy and keep heat close to Earth's surface, this trapping of heat is known as the greenhouse effect.



### ■ US Ready to plug

Enacted on November 15, 2021, the Bipartisan Infrastructure Law allocates \$1.2 trillion for U.S. transportation and infrastructure improvements, including \$550 billion for new projects. It enhances the Pipeline and Hazardous Materials Safety Administration's (PHMSA) authority, supporting its goal to ensure the safe transport of energy and hazardous materials while protecting the environment.

To know more: [U.S. DEPARTMENT OF TRANSPORTATION Pipeline and Hazardous Materials Safety Administration](#)



### ■ Carlo Gavazzi and the mobility plan

Carlo Gavazzi with its almost 50 years of experience in electric metering contributes to a greener world by supplying high-accuracy meters in various formats and characteristics for measuring the energy consumed upstream of the charging stations but also very specific meters for installation inside the charging poles.





## ■ Significant increase

The uptake of electric cars (BEVs - Battery Electric Vehicle + PHEVs - Plug-in Hybrid Electric Vehicle) and vans in US significantly increased in 2022

In 2022, the share of electric vehicles in national new car registrations increased in all US states compared with 2021, from 1.454 million to 2,442 millions.

To know more: [Alternative Fuels Data Center](#)

Electric vehicles in all states

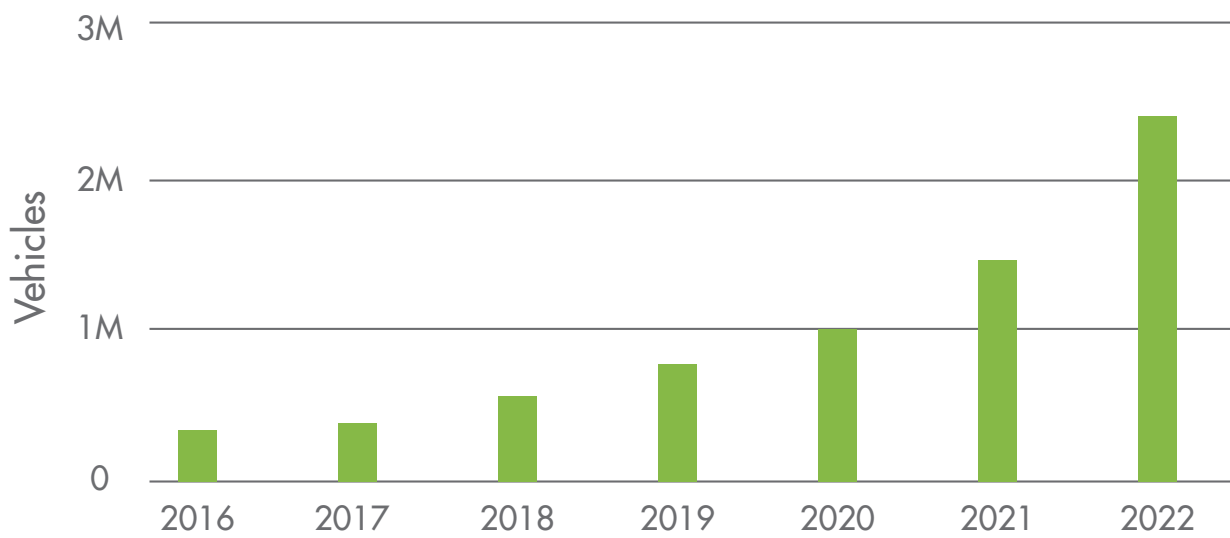

# EV charge

## Infrastructure for EV charging

### ■ AC or DC electric vehicle charging?

- **AC CHARGING**

is the leading type of plug-in vehicle charging. This technology is dominant in domestic charging.

- **DC CHARGING**

is picking up. The major charging station suppliers testing and developing solutions up to 600 kW, which would allow to charge large batteries to at least 80% within a few minutes.

Charging stations to be placed in dense urban centers and in motorways, public charging stations is not only for cars but also for vans and trucks. DC charging involves all vehicles, although the diffusion of DC fast chargers is still low.

While DC Fast Charging deployment is currently low, their deployment is increasing significantly, and this has a positive effect on consumer acceptance of EV ownership.

### ■ Slow or rapid EV charging?

- **SLOW CHARGING**

Can be found in urban areas where they can be used primarily to address the needs of electric vehicle owners that do not have access to private parking.



- Long-term parking



- From 3 to 10 hours to recharge



- AC charging

- **FAST CHARGING**

Can be found along main transportation routes and highways. It is essential for drivers to travel beyond the range of their vehicles. They also act as a psychological safety net enabling EV drivers to reduce their "range anxiety" and further increase the adoption of EVs.



- Along main routes and highways



- Approximately 30 minutes to recharge



- DC charging (mostly)

### GOOD to know

#### SLOW CHARGING AC

AC current is drawn from the charging station and subsequently converted into direct current in the car

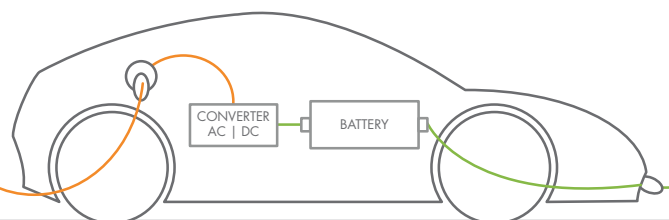

#### FAST CHARGING DC

DC current is drawn from the charging station to charge the battery, improving its overall efficiency



## ■ Infrastructure availability

The United States is prioritizing the growth of its electric vehicle (EV) charging network to accommodate the rising number of EVs. Efforts are underway to boost the number of public chargers, especially those that offer fast charging, to support long-haul EV travel. Both government and private entities are focused on deploying ultra-fast charging stations for rapid recharging, improving the appeal and practicality of EVs for a broader audience. These initiatives underscore a dedication to advancing sustainable transport and environmental objectives.



## GOOD to know

The U.S. has witnessed a significant 80% increase in Electric Vehicle (EV) registrations in the past five years, bolstered by federal and state incentives, despite some eligibility requirements. These incentives, aimed at promoting EV adoption, has led to a 20% jump in EV registrations from 2020 to 2021, with California leading the charge with 5,694 EVs per 100,000 residents. This growth reflects a strong shift towards sustainable transportation, especially in Western states.

[To know more: US News](#)

### States with the most electric vehicles registered per 100,000 people:

1	California	5,694
2	Washington	4,279
3	Oregon	4,013
4	Vermont	3,470
5	Hawaii	3,295
6	Colorado	2,868
7	Maryland	2,817
8	Massachusetts	2,742

# PV storage

## Photovoltaic storage

### ■ Let's look even further

Installing a photovoltaic system with charging station is good for saving energy and also for recharging the electric vehicle. Photovoltaic systems for the production of electricity are increasingly widespread. The electricity produced by these plants is used for variable needs and the surplus is often fed back into the grid. So combination of a photovoltaic system and electric vehicle charging could not be more appropriate.

There is only one small problem: the energy from the sun is supplied in the central hours of the day, when the car is likely to be used. Therefore, energy storage is needed to allowing drivers to charge their cars at night, avoiding the consumption of energy generated using fossil fuels in the evening.

### ■ Electric mobility with photovoltaic

Combining electric car and solar energy naturally can help to reach CO<sub>2</sub>-neutral mobility. Electric cars can increase the profitability of solar plant using energy in a better way. Instead of putting electricity into the electricity grid at an unfavourable price, it's possible to recharge the car at advantageous conditions. Only once the car has been recharged, the excess current produced will be fed into the grid.

#### Advantages of a charging station with photovoltaic:



Increase in direct consumption



Independence from the price of energy



Cheaper electric car charging



Zero-emission of CO<sub>2</sub>

#### A perfect synergy between EV and PV

- EV could use photovoltaic energy and benefit from cheap carbon-free electricity
- Photovoltaic systems could use the bi-directional flexibility of EV batteries to maximize their self-consumption

### GOOD to know

#### The power of sun

- It is the most abundant source of energy on earth
- The cost of solar panels decreased by 99% from 1997
- Solar energy is cheaper than fossil fuels
- Solar is the faster energy source to implement
- Solar power plants can last up to 40 years

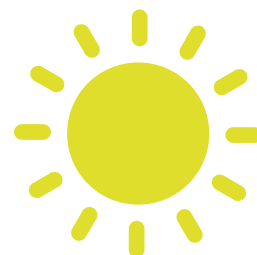



## ■ Introduction of V2G “Vehicle to Grid”

A new technology, that allows electric cars to be transformed from simple means of transport to energy carriers capable of exchanging electricity with the grid, is called V2G.

Thanks to bidirectional charging technology, the batteries of an electric vehicle will be able to stabilize the grid, storing excess energy and returning it when needed, guaranteeing benefits to the community, energy managers and those who drive an electric car.

Electric vehicle users will be able to become energy suppliers, because car batteries will be used as energy storage systems connected to the grid.

## ■ The benefits of V2G technology

The electric vehicle becomes an integral part of the electrical network, thanks to a bidirectional inverter it can store electricity in its batteries.

The benefits are various:

- Improves the electric mobility network
- Makes electric cars more attractive
- Lowers the cost of energy
- Reduces CO<sub>2</sub> emissions
- Reduces the charging costs

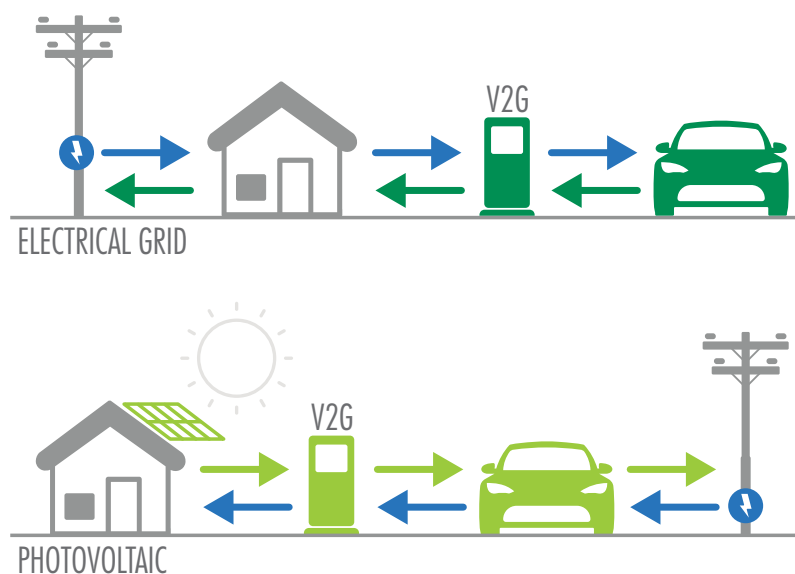

## GOOD to know

### The future of transport is electric

As part of the development of a fully electrical ecosystem, attention must be given to the size of the batteries and the cost of energy for recharging EVs.

Electric vehicle batteries hold potential beyond their initial purpose of powering mobility.

- Electric vehicles used as energy storage systems
- The network becomes more stable and efficient

# Load balancing

## EV charging

### ■ The availability of charging stations

One of the challenges for the wider adoption of electric vehicles is the availability of charging stations, in all EV charging uses. They need to be improved and smart technologies used, to make existing and new networks and EV infrastructure as efficient as possible.

### ■ EV charging is highly energy-intensive

EV charging is a high energy application that can quickly put an electrical circuit under strain if not managed properly. Electric circuits have a limited capacity and can get overloaded if too much power is drawn. To protect circuits from overloading, an electricity supply is fitted with circuit breakers which, if power use exceeds safe levels, will cut power. A circuit breaker may trip if you have had multiple high-power loads working at the same time, like charging BEVs and/or PHEVs. Of course, power can be restored by reducing the BEVs and/or PHEVs on the grid, for example, by turning OFF some of them, this might create a bad service to the car drivers.

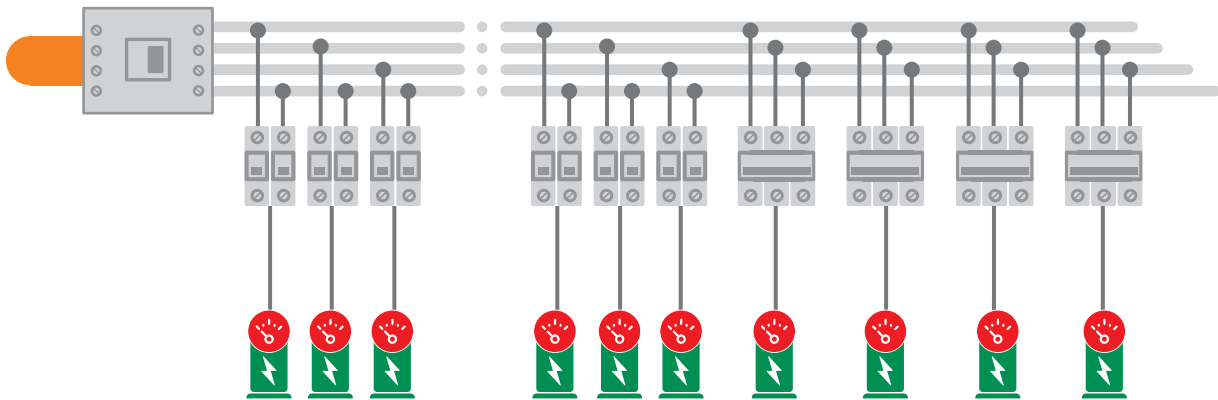

Luckily, there are a number of smart EV charging solutions available to help energy demand and the relevant electricity bill. One available feature is the dynamic load balancing.

Dynamic load balancing plays in electric car charging an extremely important role. By monitoring power loads on the circuit, dynamic load balancing intelligently allocates the available capacity to BEVs that need it the most, allowing them to run simultaneously without overloading the circuit.

### ■ Dynamic load balancing can prevent the need to upgrade the existing electrical system

In many cases, the addition of more charging poles in condominiums and public places implies the need to increase the installed power which consequently requires reviewing the electrical design of the system by changing all the cables. Dynamic load balancing solves problems like this by simply redistributing the available power to each individual charging pole intelligently so as not to create any loss of service.

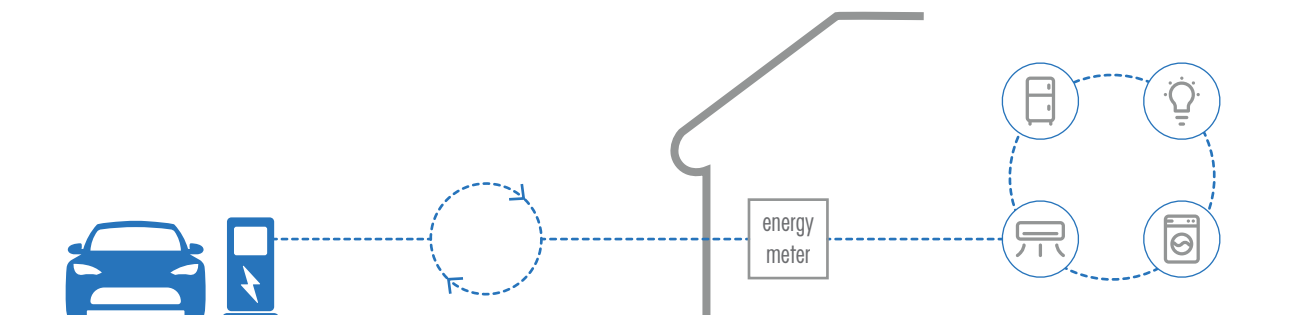

## ■ Dynamic load balancing for EVs is always a critical function

It is aimed to enable charging stations to divide available power supply between charging vehicles and ensures charge even if the charging station has limited available power supply.

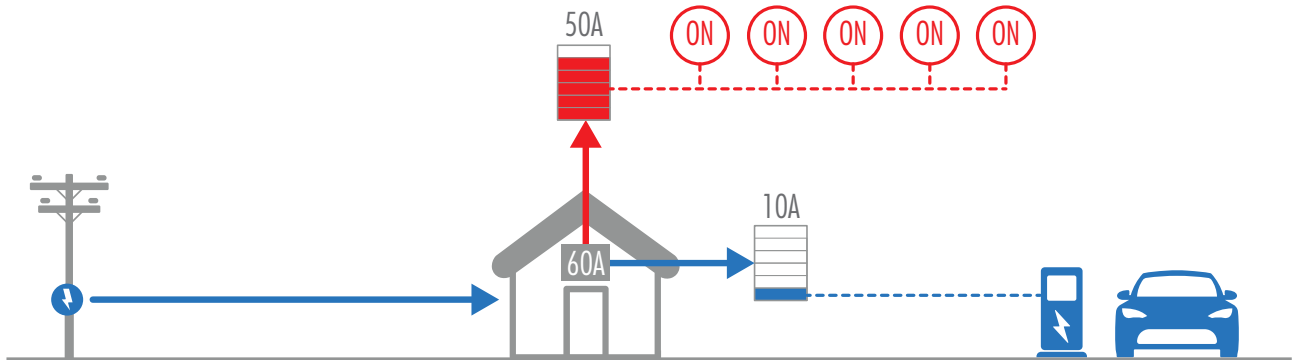

### Smart charging

Smart charging is required for load balancing so to set and control the charging management across charging stations avoiding any overload or increase of power supply costs.

Systems that deploy load balancing can be used to manage charging across multiple vehicles in a condominium, scheduling charging for example, overnight, when it is more cost-effective and can even be staggered or alternated without resulting in service lack.

## GOOD to know

### With or without Dynamic load balancing?

Without dynamic load balancing

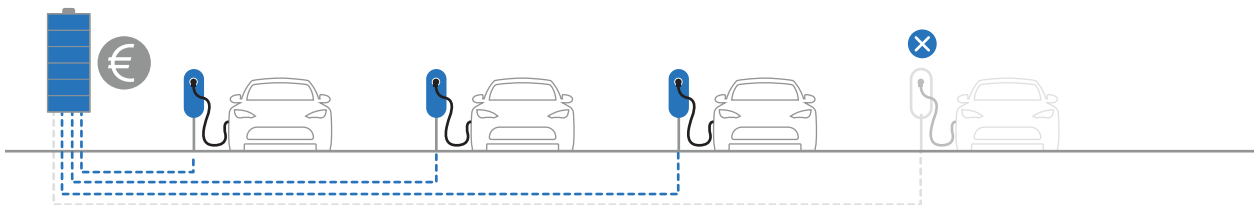

With dynamic load balancing

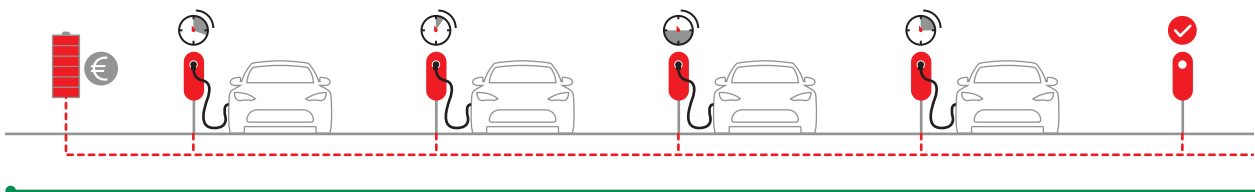

# Platform

## UWP 4.0 SE the paradigm shift

### ■ How can you implement an effective Energy Efficiency plan?

While meters can gather data, they have limited value if this information cannot be collected remotely and acted on in real-time.

Currently, a System Integrator must combine components from different suppliers to develop and automate an energy efficiency plan for their customer. The paradigm shift that Carlo Gavazzi can provide is the UWP 4.0. It is a flexible and scalable platform that acts as a remote standalone gateway for metering.

### ■ Why a unique platform?

A System Integrator using a standard monitoring and control architecture would face the following problems: system complexity, cost issues, a long commissioning time, a long learning time. The same System Integrator, using UWP 4.0 SE "Universal Web Platform" as the core of the Energy saving system would benefit of architecture simplicity, short commissioning time, cost reductions, error proof configuration, expandability, and scalability. The UWP 4.0 SE web platform with full functionalities meets today's Energy Managers and Energy Service Companies requirements to achieve energy efficiency goals.

### ■ An open system!

UWP 4.0 SE is the heart of a powerful system, it acts as a web server and a gateway which embeds various communication protocols such as Modbus TCP/IP, BACnet, SFTP, Rest API, etc. To meet the growing integration demands of IoT and cloud-based Industry 4.0, UWP 4.0 SE is certified for Microsoft® Azure IoT.

More specifically: FTP, SFTP, FTPS sends data securely and reliably on a schedule to a standard FTP server. Rest API enables the exchange of data with remote systems with the necessary flexibility. Modbus/TCP and BACnet bridges available data points using UWP 4.0 SE as a flexible data hub between fieldbuses.

UWP 4.0 SE is Microsoft® Azure certified for IoT. The available data points are sent via MQTT to the Azure IoT platform allowing users to stream data from multiple UWP 4.0 SE units to a centralized SQL or non-SQL database and from here to leverage the powerful tools from the Microsoft® Azure marketplace to analyse, organize, aggregate, and display data. In order to extend the integration capabilities of UWP 4.0 SE now also AWS IoT Core certification is available with all the advantages provided by the relevant services.

#### Disclaimer

Microsoft®, Azure, SQL Server are registered trademarks of Microsoft®. AWS and AWS IoT Core are registered trademarks of Amazon Web Services. Carlo Gavazzi has no commercial relationship with neither Microsoft® nor Amazon Web Services. Therefore all the Microsoft® and the Amazon Web Services solutions mentioned in the document must be purchased and supported through the Microsoft® and the Amazon Web Services commercial channels.





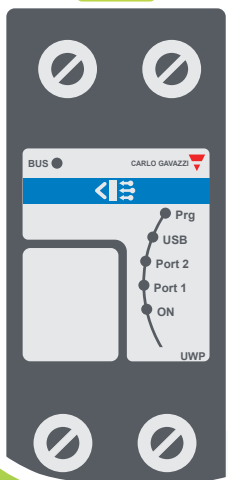

# UWP4.0 SE

## Gateway

Monitoring, data analysis and reporting

Wide control possibilities

Cost streamlining and energy saving

# Active control

## The scalable platform based on UWP 4.0 SE

to provide a full integration into a BEMS including also EV charging poles and PV storage

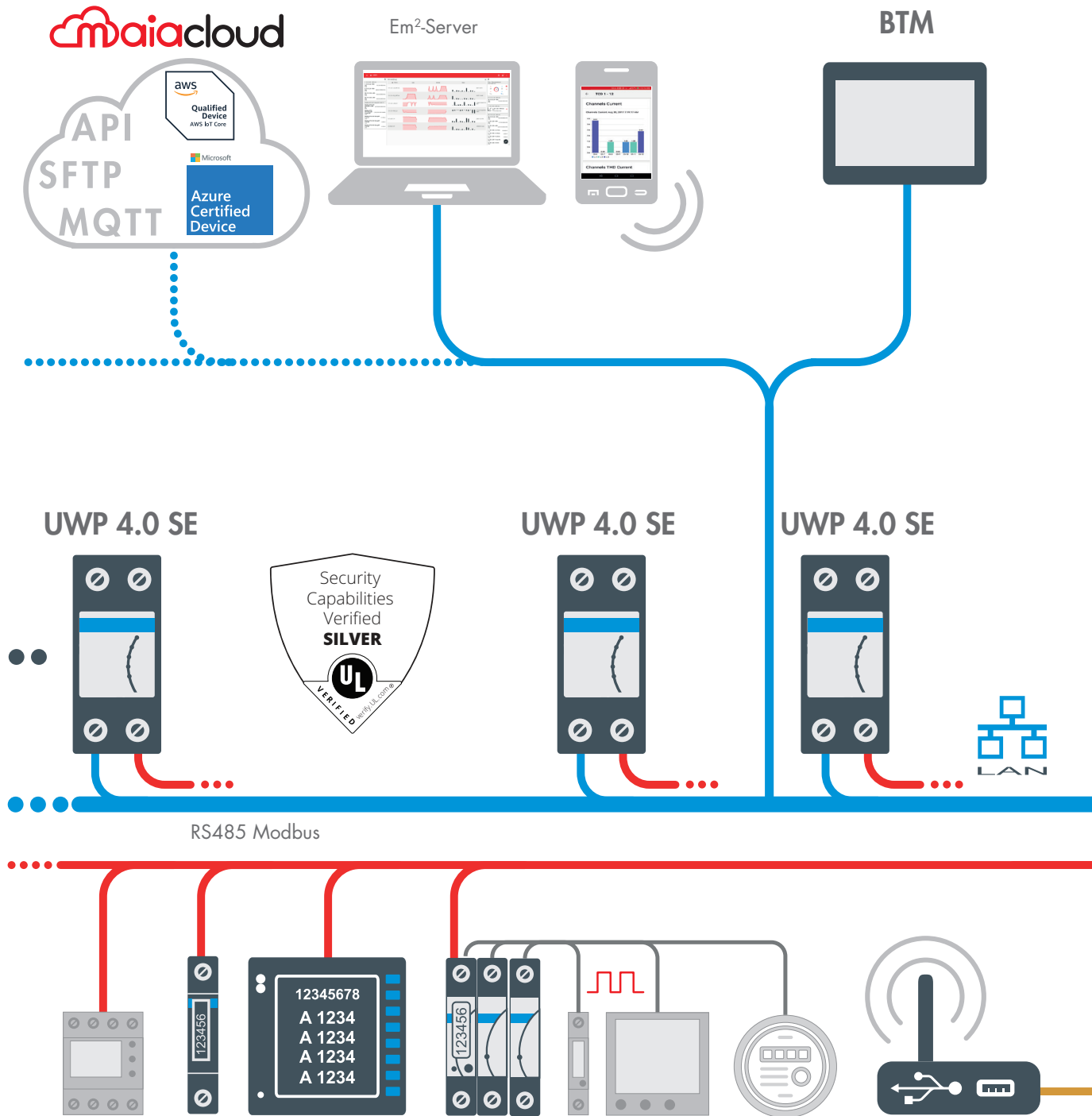

Monitoring system in the main electric panel

### Flexibility and energy efficiency

UWP 4.0 SE offers a flexible option with a number of benefits for the more demanding Energy and Building Efficiency applications which include both PV storage systems and EV charging poles. A powerful ecosystem that combines both hardware and software to effectively meet the needs of end users, the energy market, and applications, which may include redesigning of the electrical grid.

### Digitalisation and scaling-up capability

Digitalisation is the new buzzword, and IIoT evolution is the key to participating in a market that will increasingly be centred on data management to meet the demands of the future. UWP 4.0 SE Ecosystem provides a full monitoring package for integrators and energy managers who require an easy-to-deploy solution without the need to purchase pricey software and hardware integration from different suppliers.

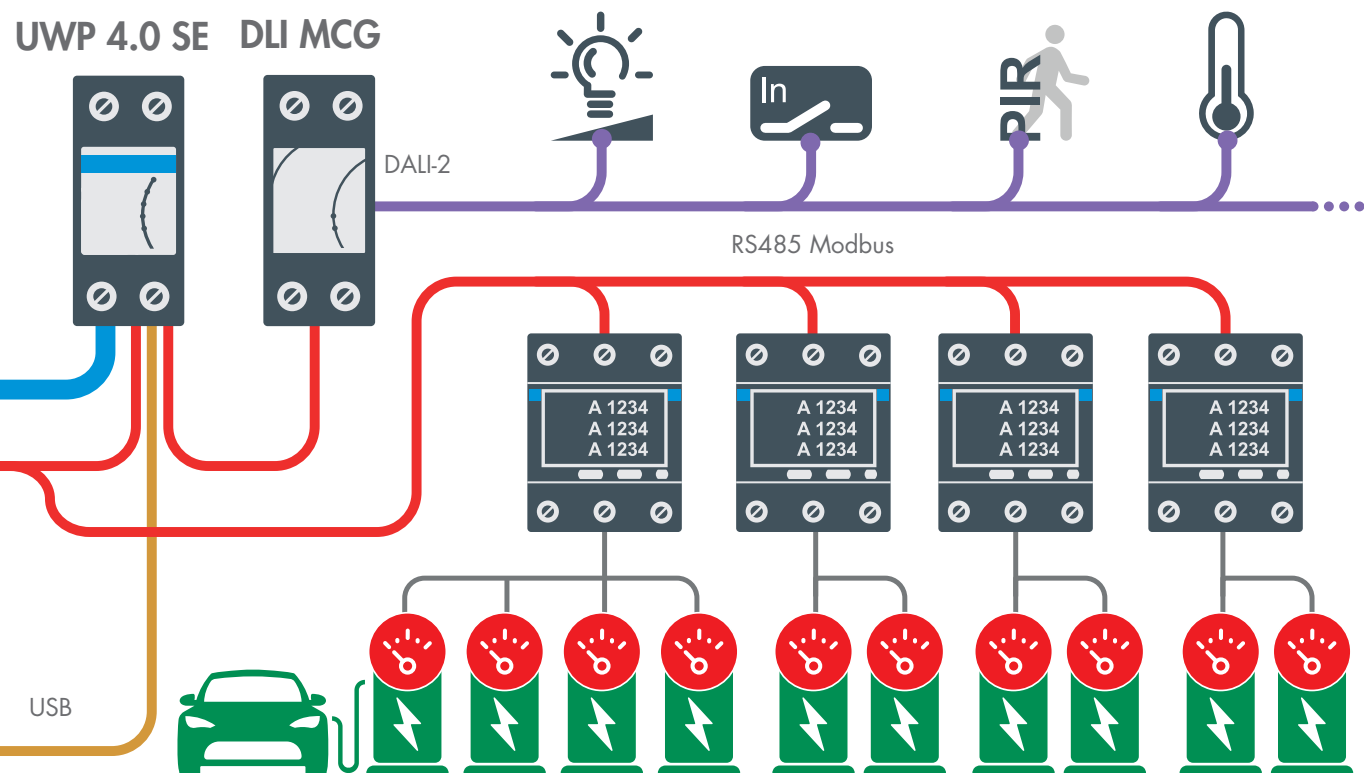

Monitoring system upstream the EV charging poles

# EV charging

## The UWP platform and the cybersecurity

### ■ The Cybersecurity as core part of the UWP web platform

#### The importance of cybersecurity in Energy Management Systems

A secure system is made up of secure components: how can you claim that your component is secure?

Very often it seems that by adding some extra security software or hardware is the only way to go.

The right advice is based on minimalism: limit the number of components in use to the bare minimum and make sure that all of them are secure enough for the application; the point is how to evaluate cybersecurity of a component.

The best way is to rely on trusted certification or ratings: a product which has undergone a cybersecurity rating or certification by a cyber lab with a good reputation gives you peace of mind that your defences will protect against the vast majority of common cyber attacks.

The EDGE level is possibly the most critical: being at the same time in contact with the operational technology (OT) part in the field and the information technology part (IT) in the cloud, it is the most sensitive brick in the IIoT paradigm. A strong EDGE level is for sure a robust foundation on which to base the whole architecture.



The UWP platform is the IIoT gateway and controller by Carlo Gavazzi for EMS systems. It is the core of an ecosystem of more than 200 meters, sensors, actuators by Carlo Gavazzi. Besides, it can be connected both at field level and at cloud level to other systems so to play as the EDGE tier in an EMS architecture.

Carlo Gavazzi is committed to provide the best security level to customers and users; for this reason UWP 4.0 SE security capabilities have been verified by UL, one of the top worldwide laboratories for cybersecurity assessment and advisory. An official rating represents a solid and secure reference for the product selection. By having solid networking foundations and encouraging customers to protect their system via VPN and passwords, the UWP Web Platform is one of the first EDGE products in the market with an official cybersecurity rating.

The need of remote connection for end-users and system integrators is almost mandatory. Typically, users want to control their devices from their smart phones, and system integrators prefer to connect from their office to their customers' plant for solving problems. This way, they avoid trip and consequently save time and money.

As is already well known, a system where end points are connected to network and each other through smart devices, cyberattacks risks - and in general cybersecurity issues - grow exponentially.

A solution to protect their remote access to the target system is a secure Virtual Private Network (henceforth VPN) tunnelling.

The VPN is the best choice to provide end-users and system integrators of end points with a secure remote access to smart phones, PC and IoT without threatening the network cybersecurity.

The goal is to guarantee the interconnection among devices, from device to external and the access to devices from outside, without mining the IT security and the sensitive data protection. The wellknown Internet services are conceived to be accessed by everyone; the so-called "public network" servers and the sensitive data are subject of fraudulent users' intrusions.

The creation of a private network (VPN) permits isolating a company network by using an IP address unreachable via Internet, with restrictions permitting the access only from external authorized devices. Moreover, the private network can be extended beyond the public network with an encrypted virtual connection.

The Carlo Gavazzi VPN for building efficiency applications including also EV charging and PV storage is MAIA Cloud. It is a PaaS (Platform as a Service) solution that allows a seamless connection of different remote devices, through UWP 4.0 SE gateways, so to develop the necessary energy efficiency monitoring and building automation solutions by connecting and setting the relevant items. Users who have access to the MAIA Cloud can easily reach the gateways and the endpoints, provided they have the necessary access rights, using a PC application called MAIA Cloud Connector.



By connecting to a centralized web portal, with a secure login, users can reach their fleet of UWP 4.0 SE units. Permissions for specific users or groups of users can be set by the organization administrator so to prevent any misuse. The VPN tunneling technology permits to set a secure encrypted channel between users and IIoT devices; the authentication procedure secures the access to the portal endpoint.

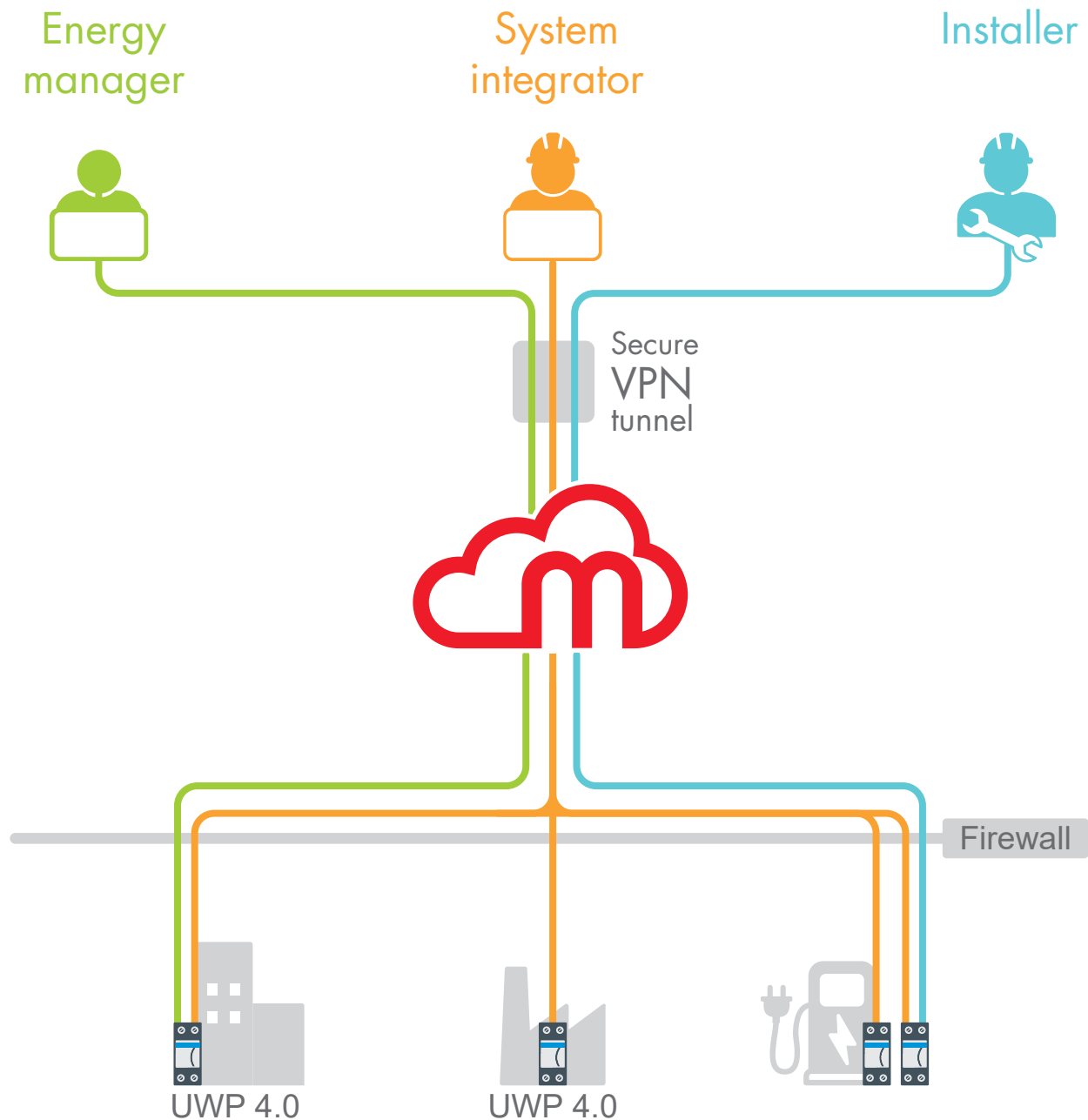

MAIA Cloud in energy monitoring and building automation OT (operation Technology) use case. Users according their roles have access to the endpoints (EDGE or FIELD devices) located in different plants. MAIA Cloud allows users with specific permission to send commands to endpoints or monitoring and manage data remotely.

# EV charging and The map

## ■ EV charging, PV storage and main switchgears

This map guides you, in this example, through the Carlo Gavazzi competences and product solutions. A journey through monitoring solutions of main instantaneous variables and energy from main electric panels to charging poles. A combination of different technical solutions aimed to integrate data from utility meters, main and sub-meters in existing or new installations!

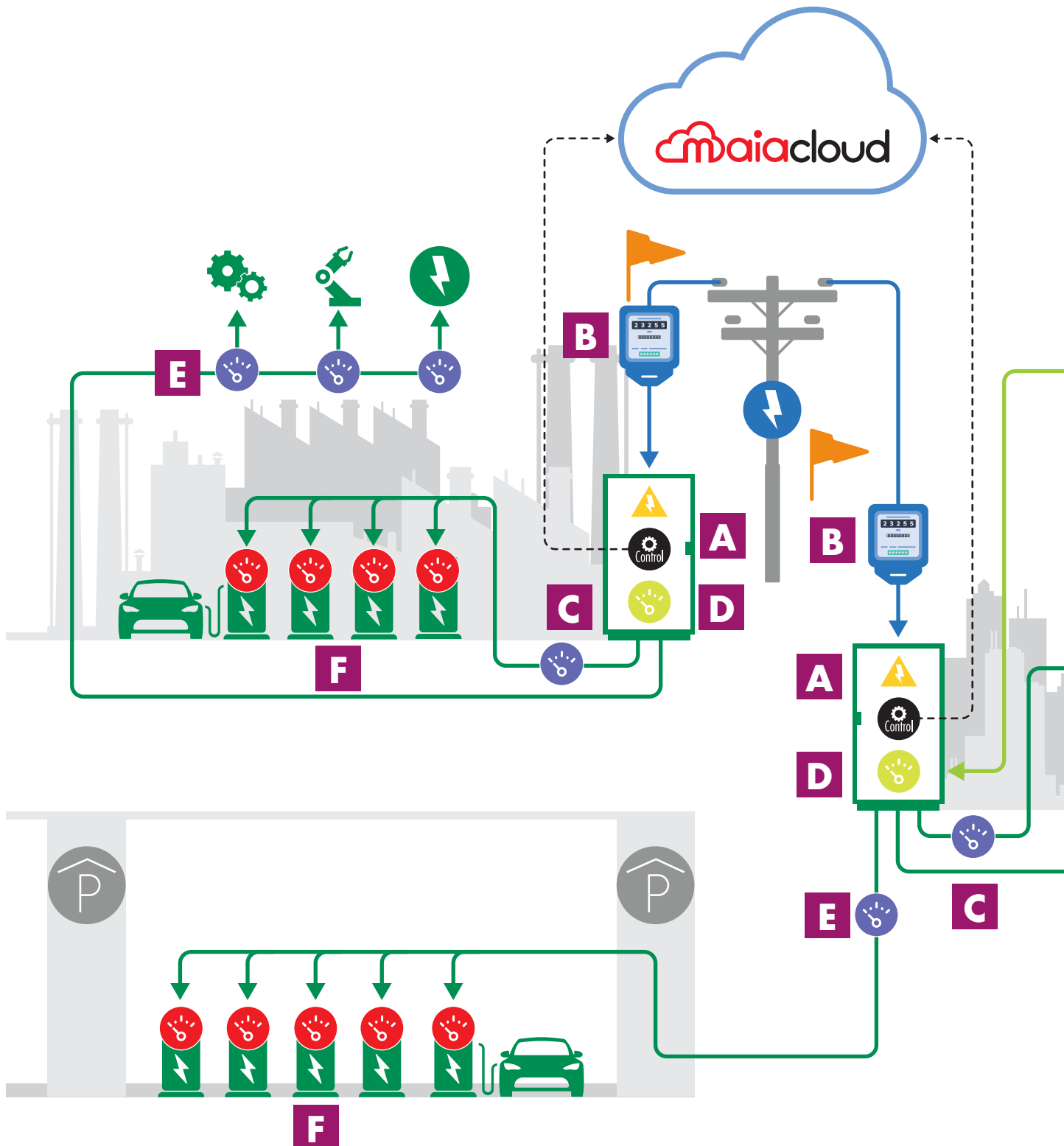

# PV storage

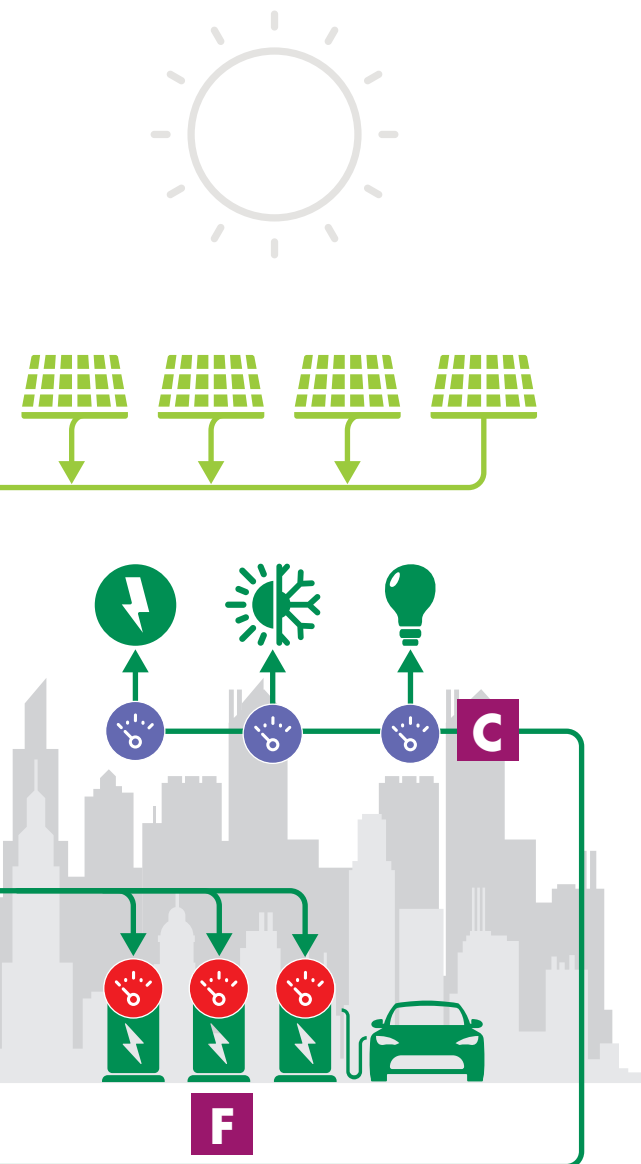

**Utilities meters**



**Main-meters**



**Sub-meters**



**Charging pole meters**



**Controls**

## The topics

	Page
<b>A</b> One platform, many integration solutions	20-21
<b>B</b> Data collection and displaying Utility, main and sub metering integration	22-23 24-25
<b>C</b> Main and sub-metering for existing and new installations	26-27 28-29
<b>D</b> Modular main metering with power analysis	30-31 32-33
<b>E</b> Quick-fit high-density metering solution	34-35
<b>F</b> AC and DC charging pole metering solutions	36-37

All products in this document are cULus approved

# Electric panel

## One platform, many integration solutions

### Communication, analysis and reporting in one unit

**UWP 4.0 SE with UL certified cybersecurity is the core of this web platform and also the unit with the task to analyse the plant variables being managed to achieve the energy efficiency goals.**

UWP 4.0 SE is the core of the entire system and can provide, as a first step, all the remote, on-premise, or cloud functionalities. Simple architecture, short commissioning time, cost reductions, error proof configuration, expandability and scalability are the distinctive characteristics of this unit. UWP 4.0 SE is a Web-Server but also a gateway. UWP 4.0 SE is Microsoft® certified for IoT. One or many UWP 4.0 SE pushing their data to the Microsoft® Azure IoT Hub will allow System Integrators to extend the level of integration to other systems. Data can be shared locally via Modbus/TCP or BACnet, while M2M makes integration with other systems possible via Rest-API or standard FTP, SFTP, FTPS communication. Excel® reports can be generated online or via the embedded scheduler. Whenever ESCOs and Energy Managers need a solution for taking control to achieve their Energy Efficiency goals, UWP 4.0 SE provides a solution to match the existing scenario.

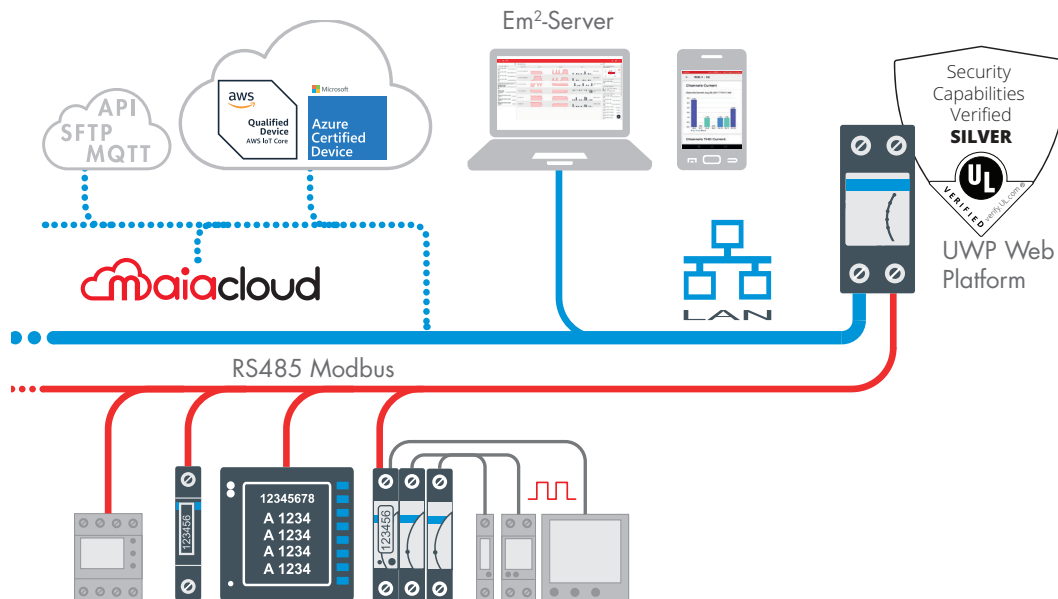

#### UWP 4.0 SE

- Micro PC with embedded Web Server, WEB services and data logger functions
- Ethernet Modbus TCP master/slave function
- 2 x RS485 ports, both of which support up to 64 Modbus devices
- Data display (charts and tables)
- Real time or scheduled data export to Excel, CSV and HTML formats
- 4GB internal memory, Back-up memory on micro SDHC and USB
- Energy analysis of each load
- Configurable dashboards with data analytics and real time display functions
- Embedded Modbus editor for compatibility with any Modbus meter
- Alarm management (e-mail or SMS by means of SH2-DSP)
- 2-DIN module housing
- 12 – 28 V dc power supply

#### The advanced functions of UWP 4.0 SE

- Embedded automation server allows data to be exchanged locally or remotely via standard Internet protocols such as: FTP, SFTP, FTPS, SMTP, Rest-API, MQTT, Modbus and BACnet
- Complete lighting control system based on DALI-2
- BACnet/IP gateway operation
- Up to 5000 managed signals (including variables, I/Os)
- Up to 5 users concurrently connected to the Web-App
- Up to 5 concurrent M2M connections (API connections, BACnet clients, Modbus masters)
- BTL certified (max 1000 BACnet points for used BACnet objects)
- USB port for external modem management



# Tools to properly display the key variables

The UWP 4.0 SE unit allows you to automate the process of collecting data points from multiple meters and other sensing units.

The embedded Web-Server allows both system integrators and Energy Managers, by means of Dashboards, to mix both history and real time data. This means, to display the key plant variables using analysis tools such as tables, trends, histograms, pies, comparison functions, which can be used also to perform diagnostics on both communication and data during plant commissioning, particularly when UWP 4.0 SE is part of a complex management architecture which may include EV charging and PV storage. Multiple user access, with authentication and granular control, allows to match any use case.

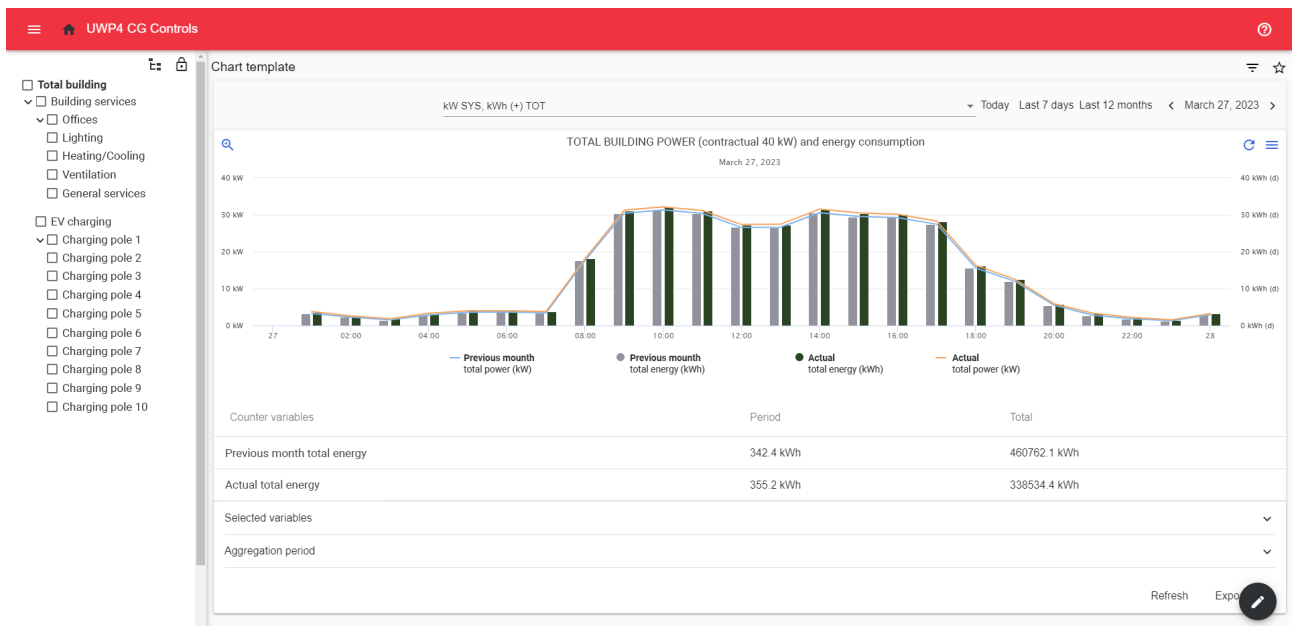

# Electric panel

## Data collection and displaying

### Many ways to collect and display data

**DALI-2 technology makes the communication easier and more flexible also in a parking place with EV charging poles**

The DALI-2 technology which Carlo Gavazzi has embedded into the DLI-MCG unit is a step beyond an energy efficiency program, since it provides through the commercial LED-based lighting systems but also through other sensors like digital inputs/output, PIRs and temperature, all accessories compatibility to transform a regular indoor car park into a smart one.

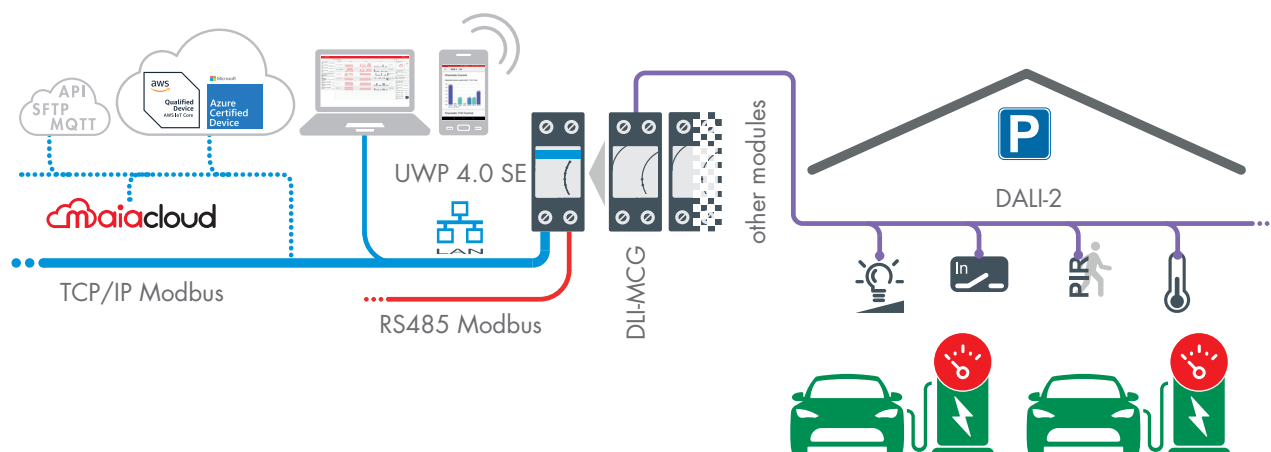

### An indoor car park with charging poles

Car parks are evolving adding also charging poles being the ideal place where to charge both BEVs and PHEVs with a regular charging cycle. In those places there is the need to provide sensors capable to detect people so to switch ON and OFF a lighting system or to manage the ventilation according to the situation so to save energy. That's why Carlo Gavazzi provides a specific user app to turn a smartphone into a powerful remote controller. It also provides a family of HMI panels with 7", 10" and 15.6" display footprint including also BTM Studio suite which is a powerful integrated development environment to design and manage a wide range of applications so to meet all the energy saving strategies.

#### BTM-T7, BTM-T10

##### BTM-T7

- 7", 800 x 480 pixel
- Dimensions 7.36\*5.79\*1.34 inches (187\*147\*34mm)

##### BTM-T10

- 10", 1024 x 600 pixel
- Dimensions 11.1\*7.76\*1.34 inches (282\*197\*34 mm)

##### BTM-T7 and BTM-T10

- TFT resistive touchscreen, 64 k colours
- 1 Ethernet port, 1 USB port, Multistandard serial port
- Linux operating system
- Fully programmable by IDE software
- IIoT data distribution via MQTT and OPC UA
- BACnet, Modbus communication protocols
- Data logging
- 24 V dc power supply

#### BTM-T15

- 15.6", 1366 x 768 pixel HD
- Dimensions 16.61\*10.51\*2.52 inches (422\*267\*64 mm)
- TFT capacitive multitouchscreen
- 16 million colours
- 3 Ethernet ports, 2 USB ports, SD card slot, multi-standard serial port
- Linux operating system
- Fully programmable by the IDE software
- IIoT data distribution via MQTT and OPC UA
- BACnet, Modbus, KNX communication protocols
- Data logging
- 24 V dc power supply

#### BTM Studio suite

This Windows suite is made by three licenses:

##### BTM-PC-IDE software

- large embedded widgets library to design and manage HMI projects
- Wide range of communication protocols to meet all different application requirements
- OPC UA server / client for Industry 4.0 applications to exchange data among HMI, PLC and devices
- MQTT service for IIoT messaging compatible with any MQTT broker
- Unified programming approach for native and web HMI applications with HTML5 and Javascript support
- Easy integration into the UWP 4.0 SE ecosystem through plug and play import of Modbus maps and EDE BACnet files

**BTM-PC-RUNTIME:** A powerful PC Runtime application turns any Microsoft® Windows® computer into a HMI panel

**BTM-PC-CLIENT:** is a viewer



# Right at your fingertips

## Apps are essential tools to control a building and its services remotely

The pages of the integrated web app, available both for Android and iOS phones/tablets, can easily be customised with graphs to monitor the consumptions and in a building also the temperature or the level of a light. Many widgets are available to remotely control any function of the system. The Web-App embedded into UWP 4.0 SE does not need a licence fee and can be operated remotely via MAIA Cloud.

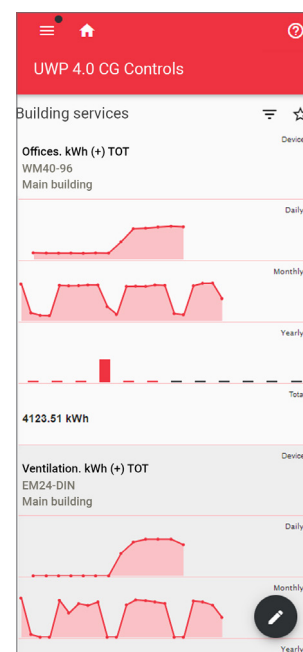
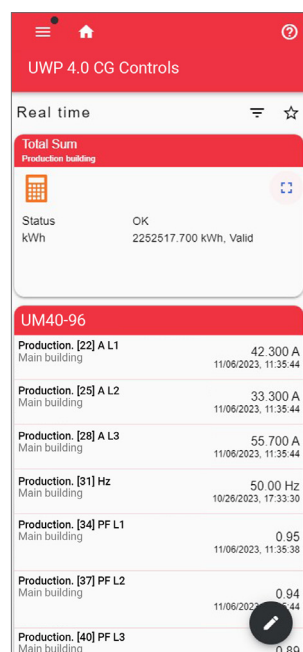
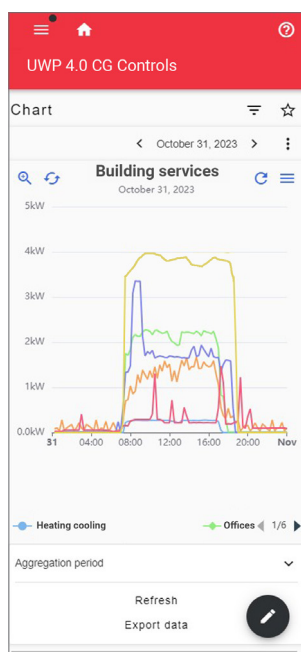



# Electric panel

## Utility, main and sub meter integration

### Existing meters

**Currently installed pulse output-based meters can still be part of a data collection system!**

In many installations, old fashioned meters are still working properly but energy information is still collected manually with both high data collection costs and potential transcription errors. Now, concentrating on multiple meters' pulse outputs and making them available as RS485 Modbus counters is possible, thanks to the modular VMU-MC + VMU-OC solution ranging from 2 to 11 pulse inputs (counters). Pulse to Modbus conversion is the key to automatic data collection, which ensures quality, granularity, and full management of data.

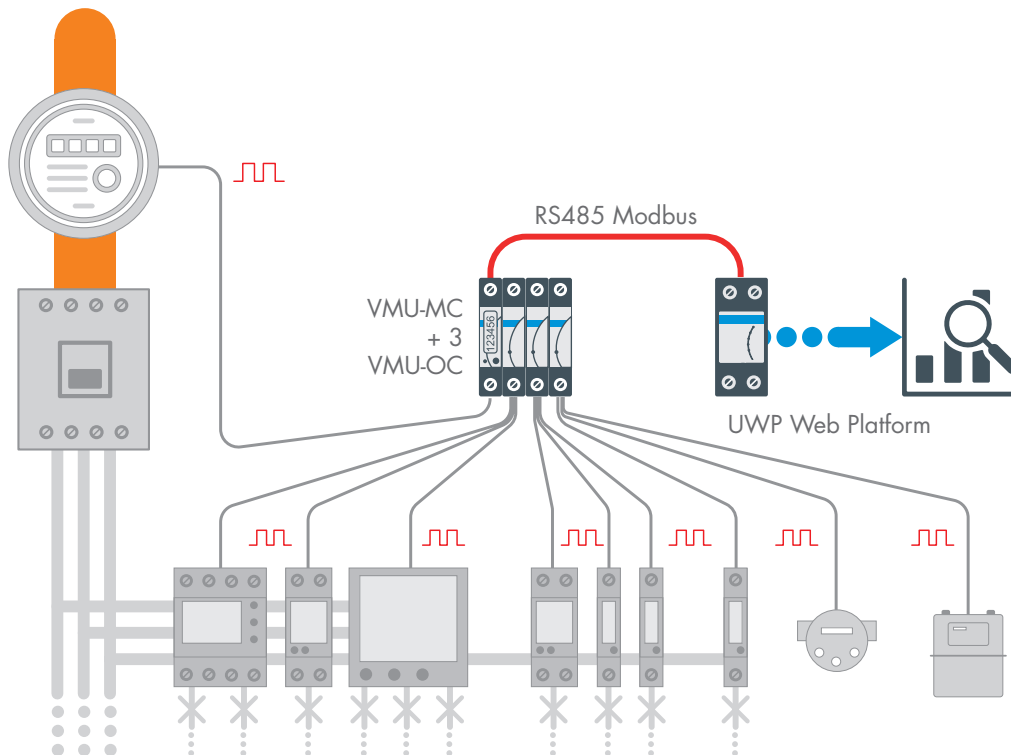

#### VMU-MC

- Master unit
- 1-DIN module housing
- RS485 communication port
- 2 inputs available (2 for pulses or up to 4 for tariffs management)
- Unit of measure: kWh, kvarh, kVAh, kJ, kcal, ft<sup>3</sup>, h, pcs, lbs
- LCD for status, counter and any active tariff displaying
- Tariff management
- One VMU-MC master unit can manage up to 3 VMU-OC slave units for maximum 2 + 9 counting inputs

#### VMU-OC

- Slave unit
- 1-DIN module housing
- Auxiliary communication bus
- 3 inputs available (for pulses only)
- Unit of measure: kWh, kvarh, kVAh, kJ, kcal, ft<sup>3</sup>, h, pcs, lbs



# The universal configuration software - UCS

The UCS software configuration advantages are available for VMU-MC and VMU-OC!

UCS desktop features, including configuring devices, storing configurations into a database, sharing configurations and logs among users and checking the device status, are available also for VMU-MC/OC. Therefore: the two VMU-MC inputs can be set as counters, or one as a counter and one as a digital input for tariff change, managing automatically the energy increase for both tariff 1 and tariff 2. Every counter input and function have an independent configurable pulse weight.

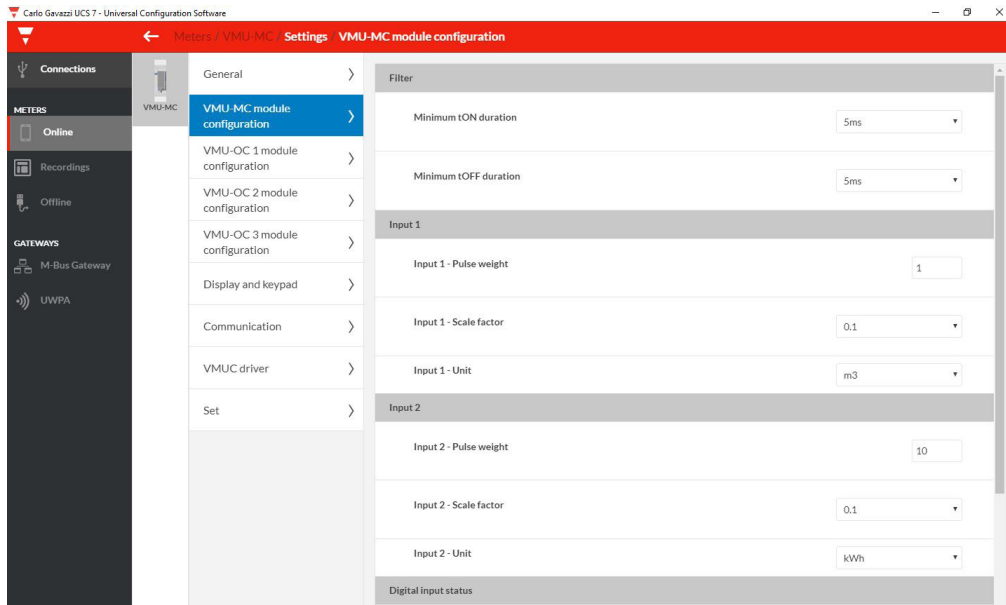

The pulses generated by both utility and sub meters are very important for monitoring energy efficiency, since the data produced drives the corrective actions for energy saving. That's why UCS desktop allows you to configure in both VMU-MC and VMU-OC the pulse signal inputs, allowing you to choose a proper ON and OFF duration time so that no pulse is lost, thus granting the highest quality and reliability of the acquisition.

But often pulse generations comes not only from watt-hour meters but also from other utility meters such as gas meters and water meters, UCS desktop software addresses this need by configuring the pulse weight, the scale factor and the engineering unit of every available input.

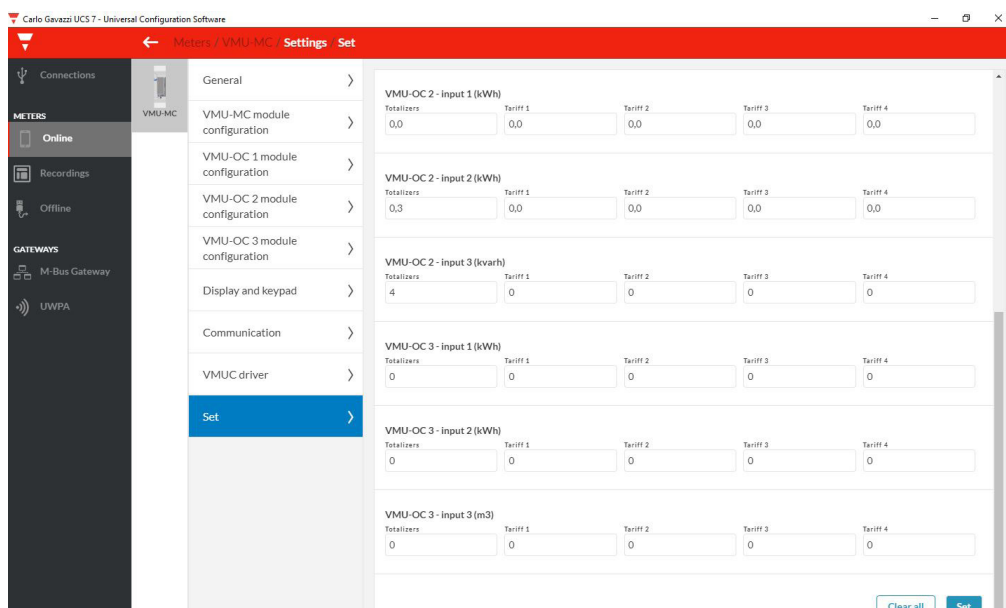

# Electric panel

## Quick-fit metering solutions

### Main and sub-metering for existing installations

The "check" part of the PDCA process starts here!

Identifying areas of energy waste with a quick installation. This portable solution is ideal for ESCOs (Energy Service Companies), and re-install it somewhere else. But it can also be the ideal solution as a part of a permanent monitoring system in a plant where communication capabilities may be restricted. EM50 has been designed to measure the electrical parameters where higher accuracy is required.

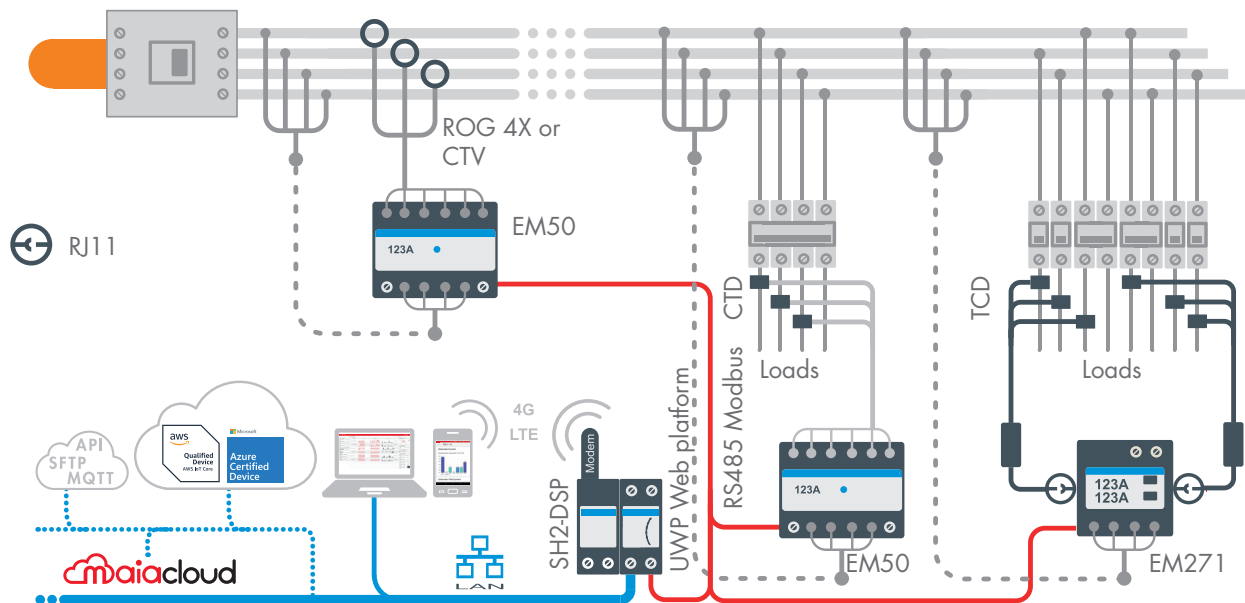

#### EM50, main and sub metering solution

- 6-DIN modules housing, 7-DGT backlit LCD display
- CT 5 A current inputs. 333 mV, Rogowski coil and 80 mA inputs for current sensors
- 100 – 600 V L-L measuring inputs
- On display: sys. and ph. +kWh, run hour meter; sys. and ph.: V L-N, A, An, W, Hz, °F
- Over bus (in addition to "on display"): tot. and tariff ±kWh/kvarh; sys. and ph. ±kVAh; 4 quadrant tot. and tariff kvarh; sys. and ph.: V L-L, var, VA, PF; demand and max. dmd: A, W, var, VA
- RS485 Modbus RTU
- 100 – 415 V ac auxiliary power supply
- Basic accuracy ±0.25% RDG (V/A), class 0.5 (kWh) according to ANSI C12-20

#### CTV and ROG 4X series, sensing solutions

- **CTV 1X-2X-3X-4X-6X-8X.** Split-core current sensing unit, 333 mV output.

Model	Primary (A)	Hole size
CTV 1X and CTV 2X	60 and 100	0.38 and 0.61 in (9.6 and 15.5 mm)
CTV 3X, CTV 4X and CTV 6X	200 and 400	0.61, 0.8 and 1.41 (15.5, 20.5 and 36 mm)
CTV 8X	800	2*3.53 in (50*89.8 mm)

- **ROG 4X.** Rogowski coil current sensors. Primary: 20 to 4000 A, diameters: 3.54, 4.72, 7.87, 11.4 in (90, 120, 200, 290 mm)

#### EM271, sub metering solution

- Patented meter, 4-DIN and 2.83\*2.83 in (72\*72 mm) solution in the same housing for DIN-rail or panel mounting. Detachable 3\*3-DGT/7-DGT display
- 208 V L-L ac and TCD-based current measuring inputs
- Current measurement by two basic TCD units with quick RJ11 plugs (see TCD M series)
- Quick configuration by automatic recognition of TCD units
- 2\*3-phase energy analysers with sum function in the same unit
- Measurements: V, A, Hz, PF, W, VA, var, bi-directional kWh
- RS485 Modbus RTU. 2 pulse outputs (loads 1 and 2)
- Self powered (120 V ac)
- Basic accuracy (kW): ±2.0 % RDG (meter + TCD M unit), kWh: class 1 (IEC62053-21)

#### TCD 0M-1M-2M-3M, MM sensing solutions

- Combination of three single split-core current sensing units

Model	Primary (A)	Hole size
TCD 0M and TCD 1M	60 and 100	0.38 and 0.61 in (9.6 and 15.5 mm)
TCD 2M and TCD 3M	200 and 400	0.61 and 0.80 in (15.5 and 20.5 mm)
TCD MM	Up to 10000(*)	See CTV series

- Basic TCD M unit (connected to three current sensors) for panel and DIN-rail mounting (\*) Compatible with current sensors with 333 mV output

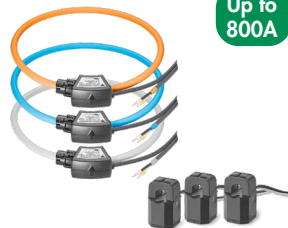

# Main and sub-metering for new installations

## Quick-fit solutions.

When installation time, meter configuration, and commissioning are a concern, Carlo Gavazzi Quick-fit is the solution. In a typical commercial installation (lighting, HVAC, heating, refrigeration) using 1+4 regular meters you can achieve a time reduction of about 70% using 3 quick-fit meters instead.

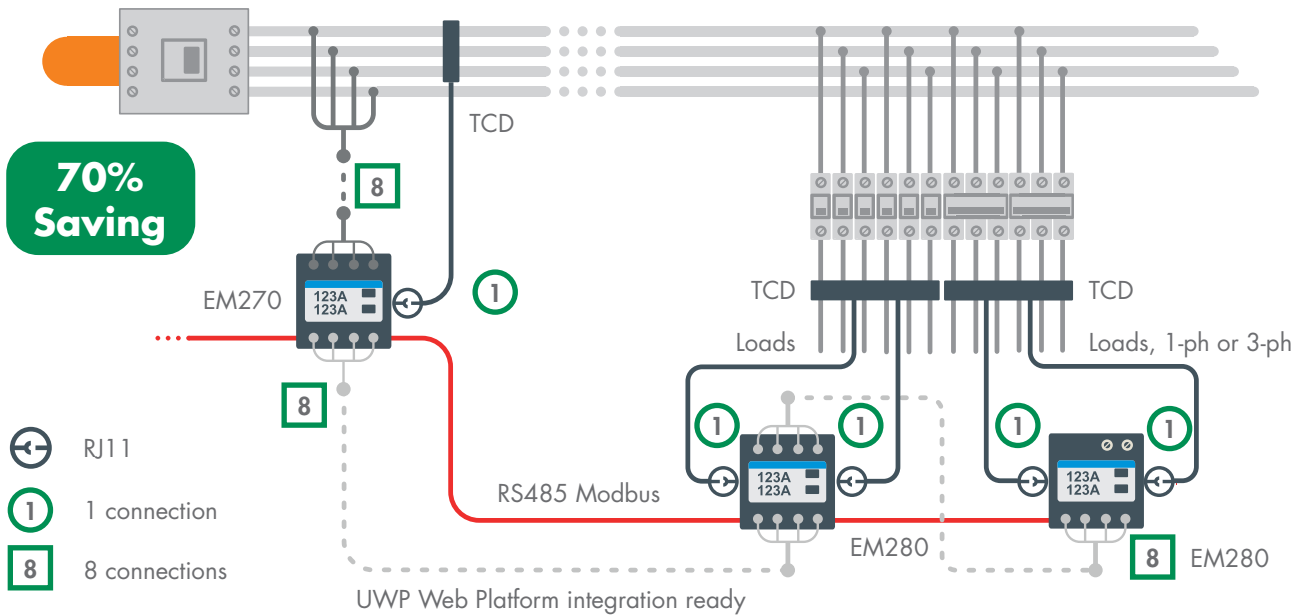

### EM270 MV6, main metering solution

- Patented meter, 4-DIN and 2.83\*2.83 in (72\*72 mm) solution in the same housing for DIN-rail or panel mounting. Detachable 3\*3-DGT/7-DGT display
- 208 V L-L ac and TCD-based current measuring inputs
- Current measurement by two triple solid-core sensing units with quick RJ11 plugs (see TCD X series)
- Quick configuration by automatic recognition of TCD units
- 2\*3-phase energy analysers with sum function in the same unit
- Measurements: V, A, Hz, PF, W, VA, var, bi-directional kWh
- Basic accuracy (kW): ±1.25% RDG (meter + TCD x unit). kWh: class 1 (IEC62053-21)
- RS485 Modbus RTU. 2 pulse outputs (loads 1 and 2)
- Self powered (120 V ac)

### TCD 1X-2X-3X, sensing solutions

- Triple solid-core current sensing unit

Model	Primary (A)	Bus-bar sizes	Center-to-center distance
TCD 1X	3*160	6.10*0.98 in (15.5*25mm)	0.98 in (25mm)
TCD 2X	3*250	0.83*0.98 in (21*25mm)	1.38 in (35mm)
TCD 3X	3*630	1.22*1.22 in (31*31mm)	1.77 in (45mm)

### EM280 MV6, sub metering solution

- Patented meter, 4-DIN and 2.83\*2.83 in (72\*72 mm) solution in the same housing for DIN-rail or panel mounting. Detachable 3\*3-DGT/7-DGT display
- 208 V L-L ac and TCD-based current measuring inputs
- Current measurement by one 6-channel solid-core sensing unit with quick RJ11 plugs (see TCD 06 series)
- Quick configuration by automatic recognition of TCD units
- 2\*3-phase/6\*1-phase energy analysers with sum function in the same unit
- Measurements: V, A, Hz, PF, W, VA, var, kWh
- Basic accuracy (kW): ±1.25% RDG (meter + TCD-06 unit). kWh: class 1 (IEC62053-21)
- RS485 Modbus RTU. 2 pulse outputs (loads 1 and 2)
- Self powered (120 V ac)

### TCD 06BX-06BS, sensing solutions

New installation, TCD 06BX	Retrofitting, TCD 06BS
6-channel solid-core current sensing unit	6-channel split-core current sensing unit
<ul style="list-style-type: none"> <li>• Primary: 6*32 A, hole size: 0.27 in (7 mm). Center-to-center distance: 0.69 in (17.5 mm). RJ11 cable length: 31.5, 59.05 or 78.74 in (80, 150 or 200 cm)</li> </ul>	

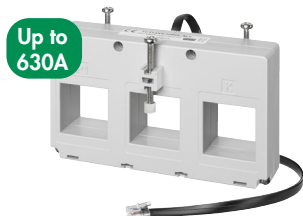

# Electric panel

## Panel mount meters

### The evolution of user needs

#### The use of analog panel meters is not only linked to cost reasons

Even today, analog ammeters and voltmeters are frequently installed in distribution boards. The choice is almost always dictated not only by cost reasons, but by the need to make any anomalies visible at a glance. The maintenance personnel in fact need to have immediate feedback on the main operating parameters in order to operate in optimal conditions both in routine and emergency situations.

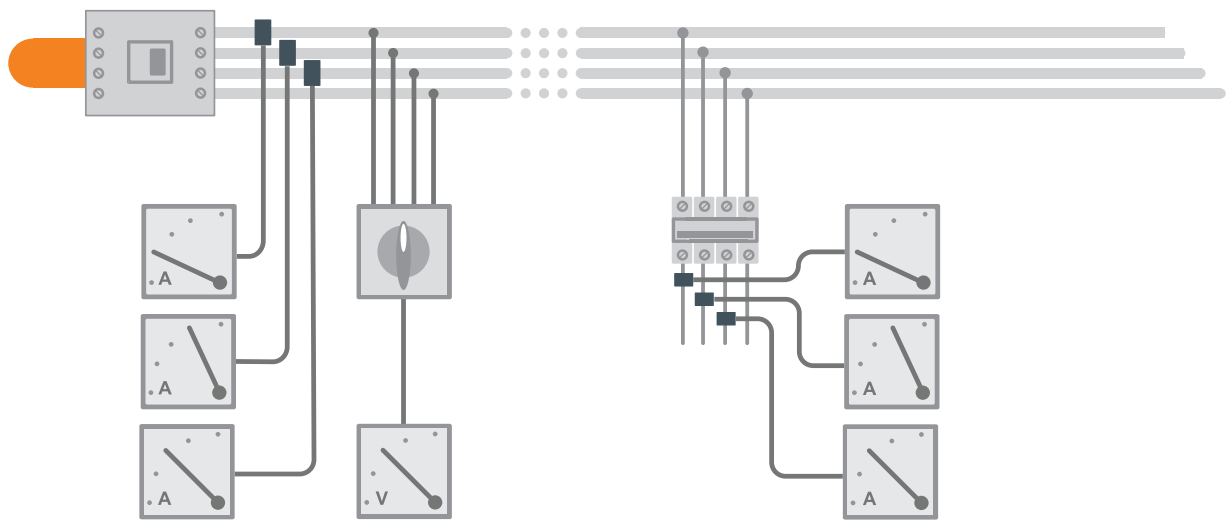

#### Users' needs change and with them the technical solutions proposed

The position of the pointer in the analog scale and the comparison among other analog panel meters on the same distribution board is preferred for the reduced effort of the user in processing the information he is voluntarily searching for (intrinsic cognitive load). But we know that the world evolves, becoming more complex and demanding. The ideal answer to this change is to offer a solution that allows an analog comparative displaying, allowing a rough but immediate understanding of the variable being measured but also, by means of a digital display, a proper accurate visualization of the same variable.

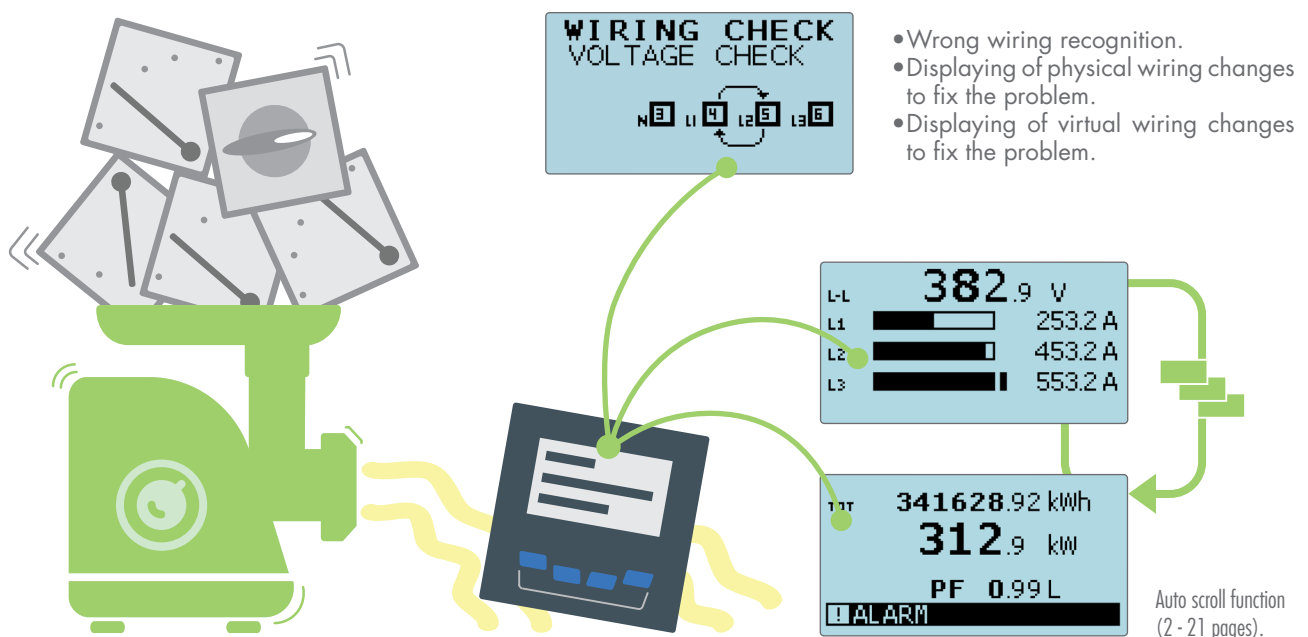

# Immediacy of visualisation and integration

## The answer to the traditional use of analogue panel meters is WM15.

WM15 is also the answer to the growing need for additional electrical variables to make more in-depth analysis. This solution condenses the information of four analogue panel meters into a single meter, but also provides an accurate measurement of power and energy thanks to the continuous and simultaneous sampling of all phases. When it is installed on a distribution board, it can relate the energy consumption to the time the EV charging pole is operating. Moreover, if an alarm is set, it can display it locally and transmit automatically and remotely all needed variables to advice about anomalies or to provide data to start a preventive maintenance plan instead.

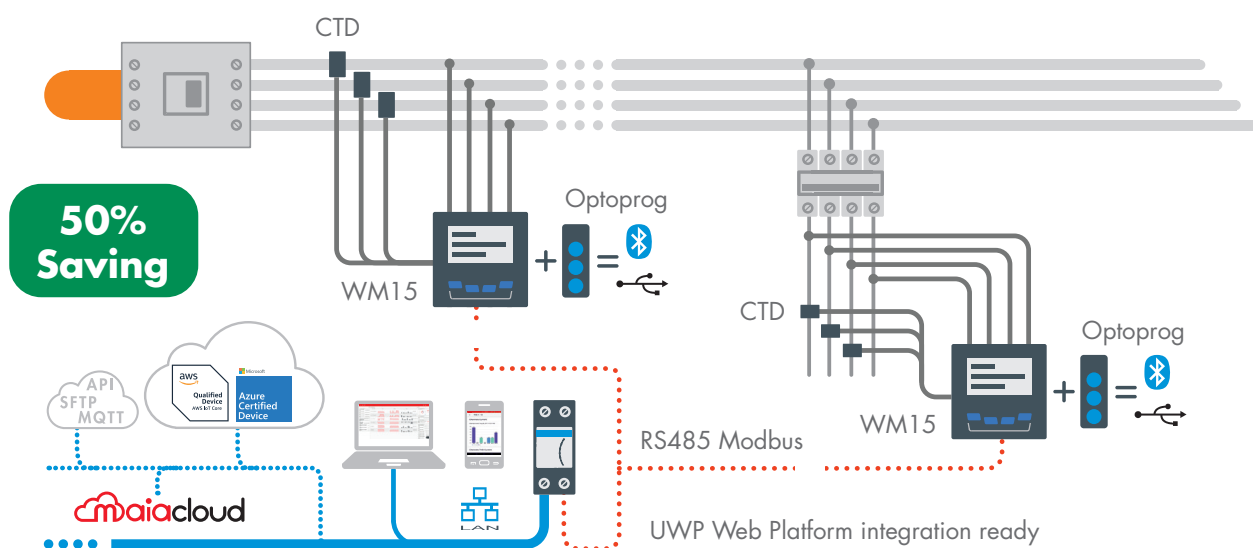

## How to reduce installation and commissioning costs

Installation and commissioning of advanced panel meters often have additional and hidden costs compared to standard analog panel meters. WM15 reduces these costs by 50% compared to a standard 4 analog meters installation and even more versus a standard power analyser installation thanks to its advanced wiring-control algorithm and its improved usability.

## The additional benefits of OptoProg and UCS in both installation and commissioning costs reduction

- The installer can check the connections and quickly change the configuration parameters using a smartphone connected via Bluetooth to OptoProg.
- The panel builder, in case of a series production of panels, can easily replicate the same configuration on all WM15 units with a single command speeding up the production process.
- In case of wiring errors, UCS provides a diagnostics of the problem encountered and can virtually correct the proper phase associations between voltages and currents, thus fixing the error without requiring further intervention.

### WM15

- 5 A current inputs for current transformers
- 120/208 V L-L measuring inputs (self-power supply)
- 480/600 V L-L measuring inputs (auxiliary power supply 120 - 240 V ac/dc)
- 3.78\*3.78 in (96\*96 mm) panel mounting, 2.32 in (59 mm) depth
- 4\*4-DGT + 3-bargraph backlit matrix display
- Bidirectional kWh and kvarh, run hour meter
- System and phase: V L-L/L-N, A, W, var, VA, PF, Hz, THD (V-A)
- Current and power demand calculation
- Static output for pulse transmission or alarm
- RS485 Modbus RTU port (100 ms data refresh)
- Basic accuracy (V/A):  $\pm 0.5\%$  RDG, kWh class 1 (IEC62053-21)

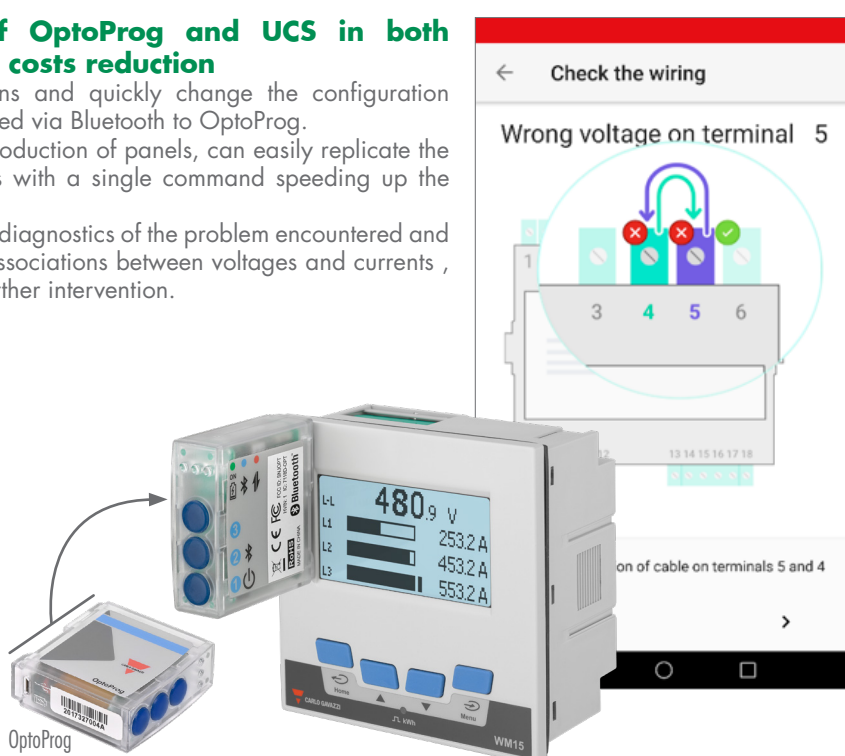



# Electric panel

## Beyond panel mount meters

### Modular main metering with power analysis

**A high-spec meter is often time demanding due to its installation and commissioning complexity: how can you make it time and cost effective?**

Yes, by selecting the most appropriate device to meet the different installation and application needs among the three available power analyser models. Metering capabilities, and control functions, as well as a common modular system are the key features. Panel Builders, System Integrators and Installers enhance and speed up their activities of initial meter configuration, communication diagnostics and commissioning with the help of the combination of new and innovative tools like OptoProg, UCS desktop, and UCS mobile. This family, due to its very high accuracy class is also the answer to "Green Mark" and other green building benchmarking schemes requirements.

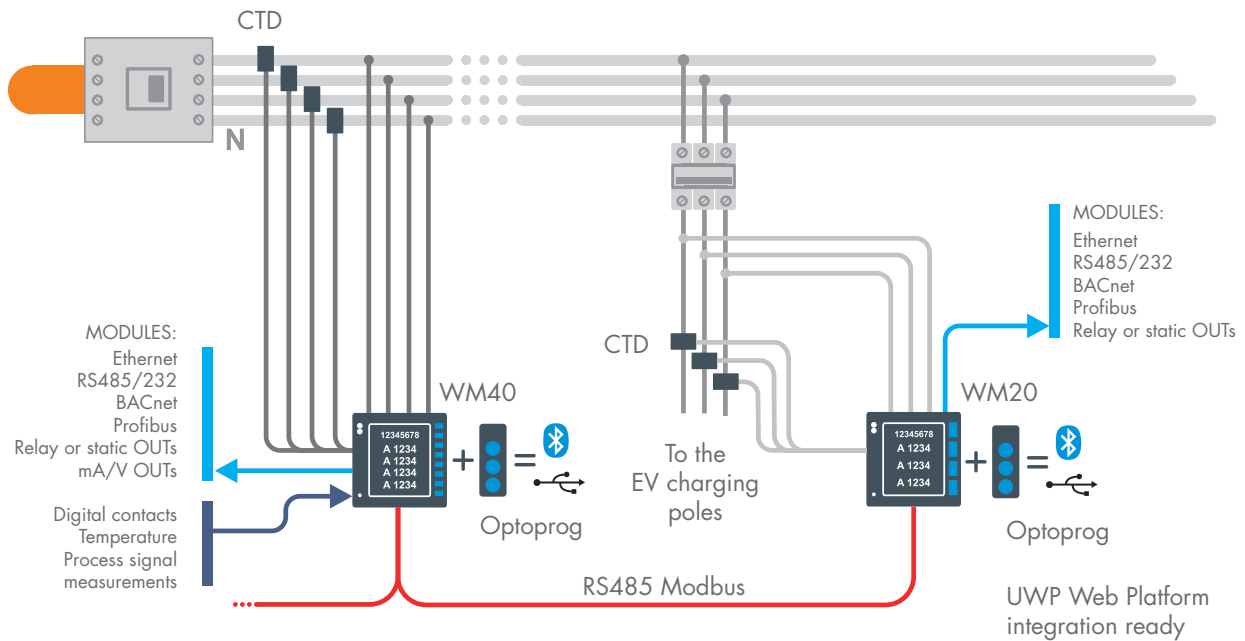

#### WM20

- 3.78\*3.78 in (96\*96 mm) panel mounting housing with front protection degree, NEMA4X/12 (IP65)
- 5 A current inputs for current transformers
  - Up to 793 V L-L measuring inputs
  - Basic accuracy (V/A):  $\pm 0.2\%$  RDG
- Single and three-phase measurements: V, A, An, Hz, PF, W, VA, var, run-hour, kvarh, bi-directional kWh (cl. 0.5s IEC62053-22)
  - 9+1-DGT counter variables, backlit LCD display
  - Modular housing (see the modules list besides)
  - Optical port for fast data reading and configuration
- THD analysis up to 31st harmonics with source detection, single harmonics via Modbus
- 3\*4 DGT instantaneous variables, LCD display
- Max values of all power variables
- Automatic scrolling pages
- 2 freely configurable virtual alarms

#### WM30

- 4\*4 DGT instantaneous variables, LCD display
- Avg and max values of all system and single phase variables
- 4 freely configurable virtual alarms
- Real time clock
- Other features, same as WM20
- 4-tariff management
- Factor K and TDD metering
- 16-alarm PLC logic and digital inputs for utility metering, built-in event and data stamping for instantaneous variables and load profiling
- Other features, same as WM30

#### WM40

- 4-tariff management
- Factor K and TDD metering
- 16-alarm PLC logic and digital inputs for utility metering, built-in event and data stamping for instantaneous variables and load profiling
- Other features, same as WM30

#### Modules

- WM20/WM30/WM40
- RS485/RS232 Modbus RTU
  - BACnet IP
  - BACnet MS/TP
  - Ethernet (Modbus TCP)
  - EtherNet/IP (WM20 excluded)
  - Profibus DP-VO
  - 2-static and relay outputs
- WM30
- 2\*20 mA dc or 2\*10 V dc outputs
- WM40
- Up to 4\*20 mA dc or 10 V dc outputs
  - 6-channel digital inputs, up to 6 relay/8 static outputs + OR/AND alarm logic management
  - Direct An + Temperature + Process signal measurements

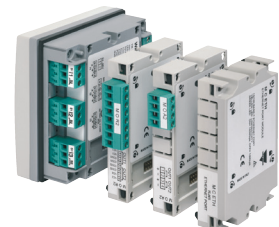



# Advanced configuration and commissioning tools

**An innovative solution to drastically reduce both configuration and commissioning time!**

The installation, the configuration, and the commissioning of a power analyser has an intrinsic complexity which is due not only to the product itself, but also to the sequence of events which usually starts in the workshop of a Panel Builder and moves to the plant for the final installation. Hence, one product, which for different reasons and in different contexts moves through different professionals. To be able to be effective, there is the need to be able to supply a tool matching the skills and needs of different people. OptoProg, with its App, or simply as desktop software, is the best answer to simplify the whole process.

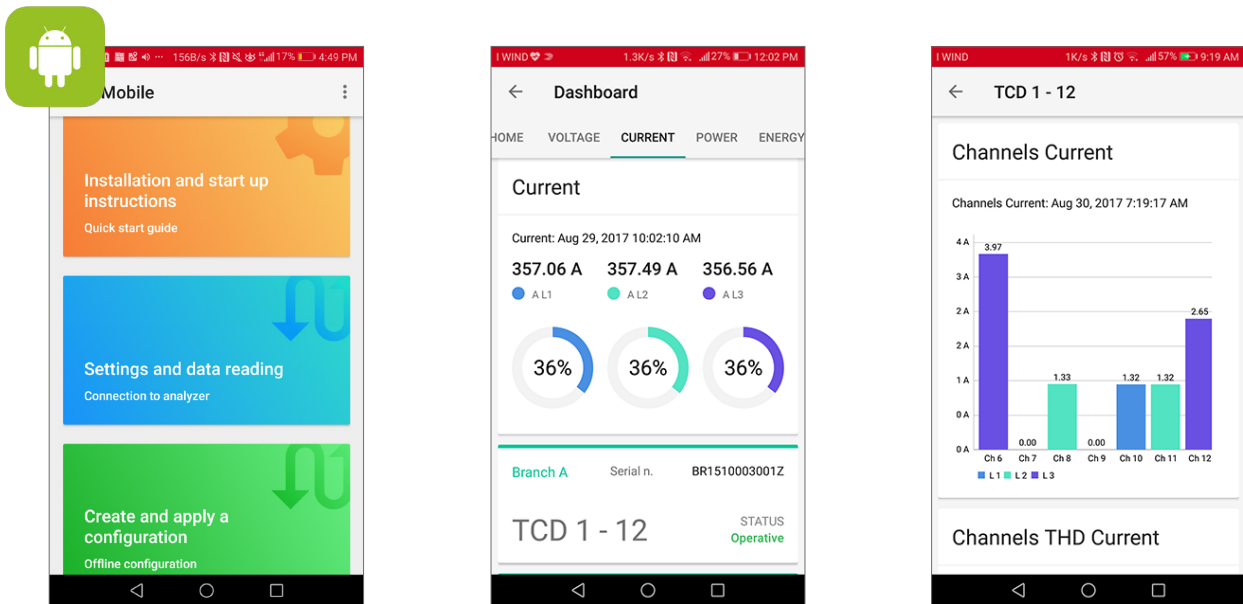

OptoProg is an optical port-based coupling unit with built-in rechargeable battery, provided with both USB and Bluetooth communication capabilities to be used in combination with either UCS desktop or UCS Mobile (Android), with its excellent usability, allows the Panel Builder to set all initial metering parameters without physically using the meter front keypad. If the panel is produced in series with the same overall characteristics and meter settings, by using the configuration upload and download function, the process is further shortened and error free. Once the distribution board with the power analyser is on site, the System Integrator using its OptoProg unit and UCS software can download the meter configuration parameters, change them, add alarms and upload the new configuration to the power analyser again to complete the process. With the same UCS it is possible to test the communication to other devices in the same Modbus network. The whole configuration process can be performed without opening the distribution board door, making this process more efficient, effective and safe. Once everything is done, just remove OptoProg from the power analyser and install it on another meter.

## OptoProg

- Bridge mode use with embedded optical port
- Built-in lithium battery for one month operations
- Sleep mode for energy savings
- Configuration and communication status LED
- Bluetooth 2.0, 2.1, 3.0 and 4.0 connectivity
- Micro-USB B port
- CCC and IC certified



OptoProg is compatible with: WM15, WM20, WM30, WM40, WM50.

# Electric panel

## Utility, main and sub meter integration

### The universal configuration software

**UCS, the universal configuration tool continuously upgraded and compatible with all Carlo Gavazzi meters.**

In addition to the standard display of variables, functionality and configuration parameters, it is common the need to be more effective and efficient during first meter configuration (by the Panel Builder) and site commissioning (by the System Integrator). UCS, the Universal Configuration Software, is the answer, providing a full set of effective tools for meter configuration, variable displaying and communication diagnostics. These tools are aimed to be quick and to help the different professionals, such as Panel Builder, Installer, System Integrator, and End-user, to limit and fix any installation, configuration, and commissioning error.

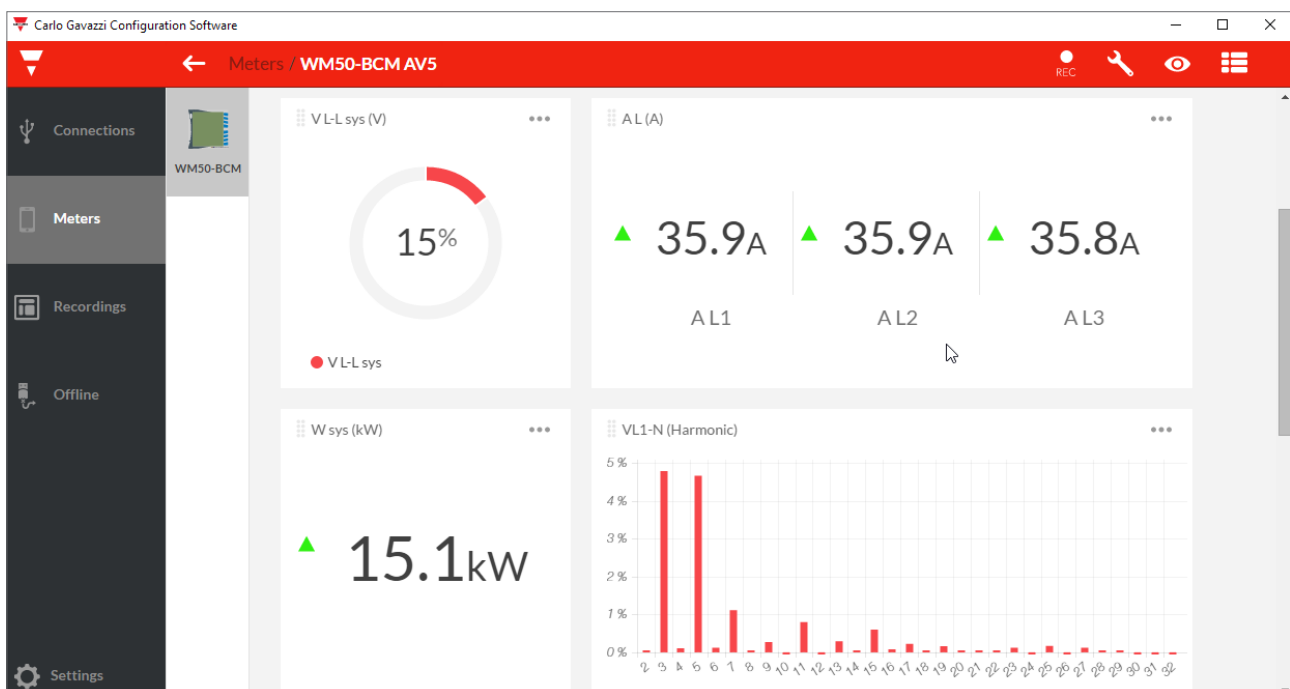
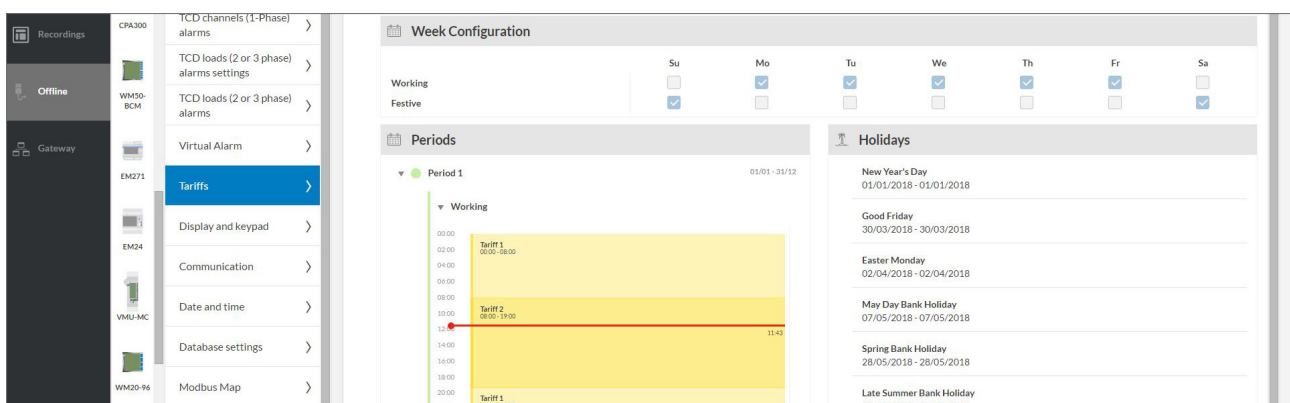
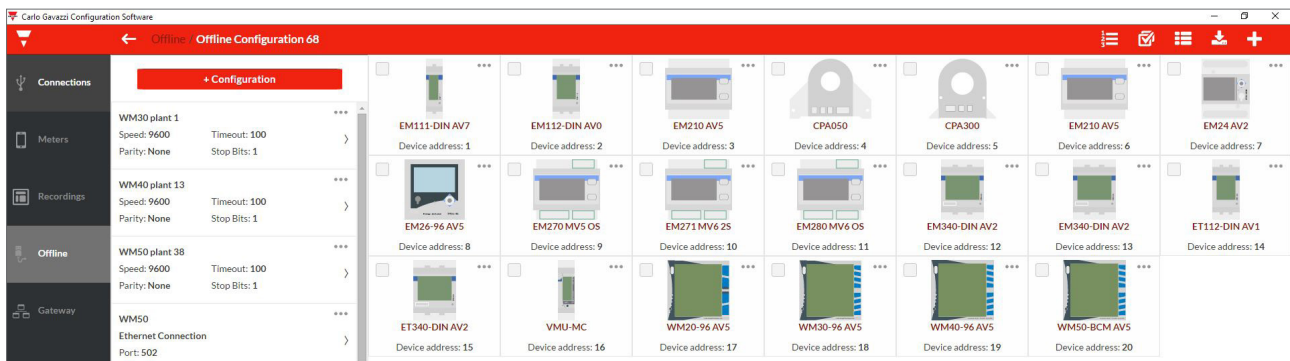

# Solid-core and split-core current adapters

From compact sizes to high currents and from solid-core to split-core, these are the current adapters for Carlo Gavazzi meters and the appropriate solution for any kind of installation.

## CTD 1/2/3/4-X

CTD	from (A)	to (A)
1x	50	300
2x	40	600
3x	50	800
4x	150	1600

- Solid core for cable or bus-bar
- Cable diameter: 0.90 to 2 in (23 to 51 mm)
- Bus-Bar: 0.79\*0.20 in to 2.5\*0.79 in or 2\*1.69 in (20\*5 mm to 64\*20 mm or 51\*43 mm)
- Secondary: 5 A (standard), 1 A (available upon request)
- Sealable terminal covers
- IEC61869-2 compliant

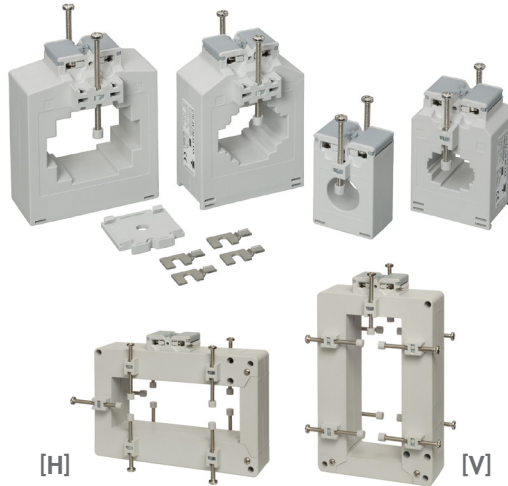

## CTD 8/9/10-V-H

CTD	from (A)	to (A)
8 V/H	150	1600
9 V/H	400	2000
10 V/H		

- Solid core for cable or bus-bar
- Bus-Bar: 1.22\*3.19 in to 2\*4.96 in (31\*81 mm to 51\*126 mm)
- Secondary: 5 A (standard), 1 A (available upon request)
- Sealable terminal covers
- IEC61869-2 compliant

## CTD 5/6-S

CTD	from (A)	to (A)
5 S	100	400
6 S	150	1000

- Split-core for cable or bus-bar
- Bus-Bar: 1.02\*1.25 in, 1.97\*1.26 in (26\*32 mm, 50\*52 mm)
- Secondary: 5A (standard), 1 A (available upon request)
- Sealable terminal covers
- IEC61869-2 compliant



## CTD 8/9/10-S

CTD	from (A)	to (A)
8 S	150	1600
9 S	400	2000
10 S		

- Split-core for cable or bus-bar
- Bus-Bar: 1.22\*3.19 in to 1.97\*4.92 in (31\*81 mm to 50\*125 mm)
- Secondary: 5 A (standard), 1 A (available upon request)
- Sealable terminal covers
- IEC61869-2 compliant

## CTA 5/6

CTA	from (A)	to (A)
5 X	100	300
6 X	200	600

- Split-core for cable
- Secondary: 5 A
- Cable diameter: 0.94 in (24 mm) (5X), 1.42 in (36 mm) (6X)
- IEC61869-2 compliant



# Electric panel

## Quick-fit high-density metering solution

### Distribution board-based solution

In a single solution the combination of a three-phase main meter with CT inputs and 65A integrated TCD sub-meter units with up to 96 single-phase channels or 32 three-phase channels.

When the electrical system is different from a bus-bar trunking or bus-duct system, and numerous EV charging poles are fed from a common distribution board, than WM50-96 is the ideal solution for branch circuit monitoring. The solution is based on one core unit WM50, which is usually installed and connected on the mains, and some TCD12 units as combined meters installed downstream the MCBs for single phase or three-phase EV charging poles. As the whole installation cost derives not only from the cost of the components, but even more by installation and commissioning costs, this innovative solution allows you to achieve more than 75% installation and commissioning savings vs. standard solutions.

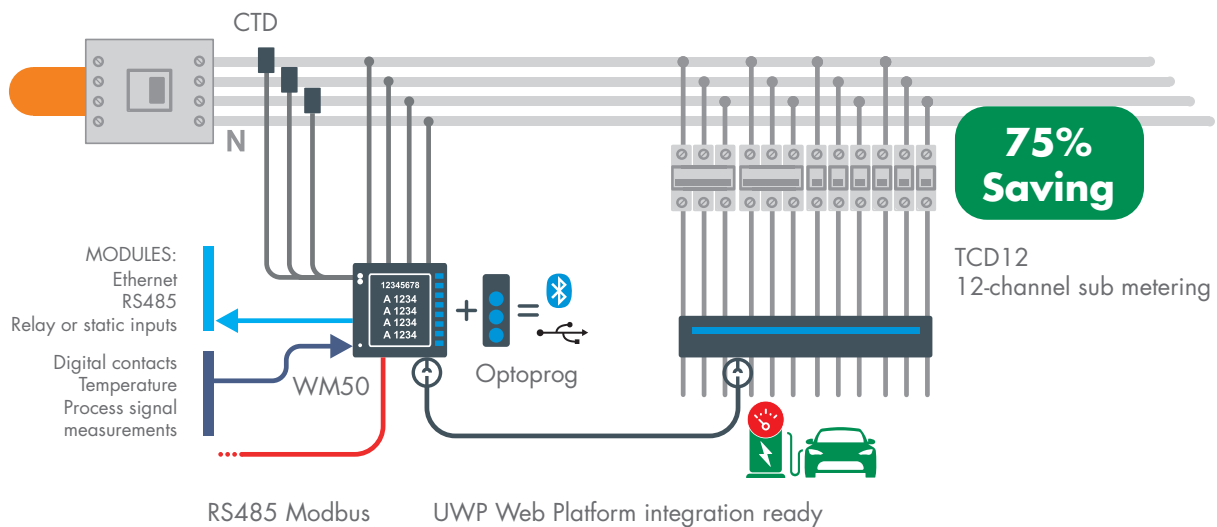

#### WM50, main metering solution for distribution boards

- 3.8\*3.8 in (96\*96 mm) panel mounting meter with NEMA4X/12 (IP65) front protection degree and modular housing
- Up to 480 V L-L ac and 5 A CT measuring inputs
- Single and three-phase measurements: V, A, An, Hz, PF, W, VA, var, run-hour, kvarh, bi-directional kWh (cl. 0.5S IEC62053-22), THD analysis up to 31st harmonics, single harmonics via Modbus
- Basic accuracy (V/A):  $\pm 0.2\%$  RDG
- 9+1-DGT totalized and 4-DGT instantaneous variables LCD display
- Optical port for fast data reading and configuration
- Universal power supply (90 – 260 V ac/dc)
- 4-tariff management
- 16-alarm PLC logic and digital inputs for utility metering, built-in event and data stamping for instantaneous variables

#### WM50, I/O optional modules

- RS232/RS485
- Ethernet (Modbus TCP)
- 6-channel digital inputs, up to 4-relay/6-static outputs + OR/AND alarm logic management
- Direct An + Temperature + Process signal measurements

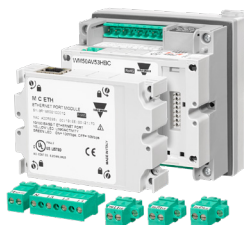

#### TCD12, 12-channel sub metering

- Primary: 12\*65A
- Hole size: 0.33 in (8.5 mm)
- Center-to-center distance: 0.69 in (17.5 mm)
- RJ cable length: 11.8 to 196.8 in (30 to 500 cm)
- 12-channel split-core current sensing unit
- Accuracy Class 2 (kWh) according to IEC62053-21 (meter + TCD unit)
- Up to 96 channels: kWh, W, var, VA, PF, A, THD A
- Data available via communication module on board of WM50



# Power Bus-bar trunking based solution

## Why a high-density metering solution?

In an industrial or commercial installation, in the same facility, the purpose of metering is not only load monitoring but also to establish energy cost centres for cost allocation including, for example, charging costs of employee's electric vehicles. Moreover, a modern industrial site, for power availability needs, is equipped with a genset or, because of a need to implement an energy efficiency and sustainability plan, with a PV plant. In these examples, a meter capable of measuring energy in the four quadrants so as to distinguish between consumed energy and generated energy is even more important. Moreover, to complete the full electric analysis of loads it is important to measure their inductive or capacitive consumed energy, thus helping to monitor their correct working and preventing potential failures. In all these cases, with its advanced metering functions, EM50 is the ultimate answer.

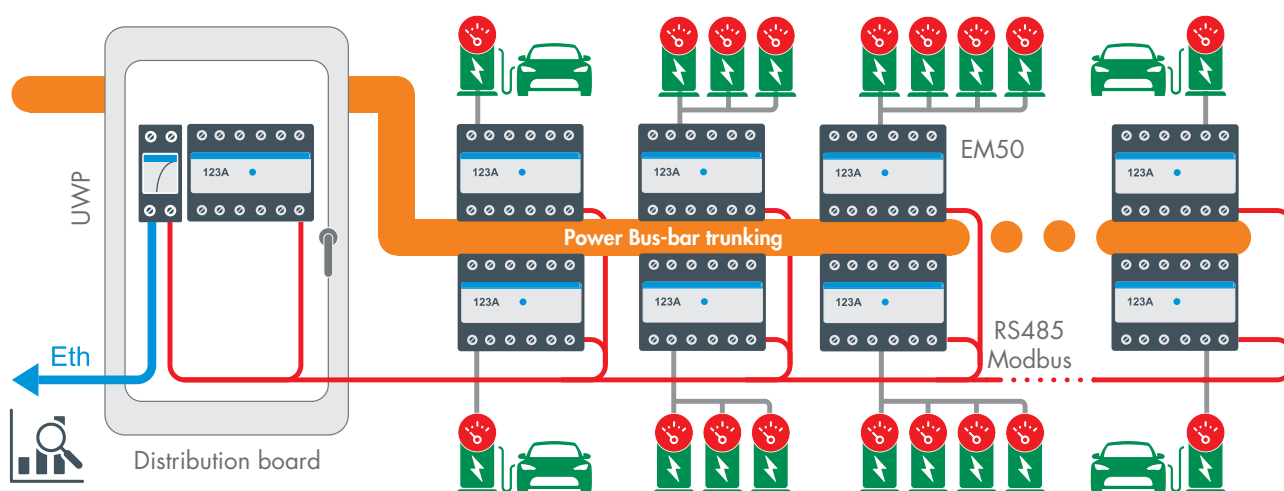

### EM50

- CT 5 A current inputs. 333 mV, Rogowski coil and 80 mA inputs for current sensors
- 100 – 600 V L-L measuring inputs
- 100 – 415 V ac, 100 – 300 V dc auxiliary power supply
- On display: imported system and phase kWh, run hour meter; system and phase: V L-N, A, An, W, Hz, meter temperature
- Over bus: bidirectional total and tariff kWh/kvarh, run hour meter; bidirectional system and phase kVAh; four quadrant total and tariff kvarh; system and phase: V L-L/L-N, A, An, W, var, VA, PF, Hz, meter temperature; demand and max. demand: A, W, var, VA
- 7-DGT backlit LCD display
- 6-DIN modules housing
- Basic accuracy  $\pm 0.25\%$  RDG (V/A),
- Class 0.5 (kWh) according to ANSI C12-20, Class 0.5S (kWh) according to IEC62053-21
- Tariff management via internal calendar/clock
- Monthly energy log, 4-quadrant reactive energy

- Event log and alarm management (12 alarms)
- RS485 Modbus RTU or BACnet MS/TP port Digital output for pulse transmission or alarm
- Relay output for alarm or remote-control function
- Measurement Canada approved for fiscal metering





# Charging poles

## A compact range of DIN rail mount meters

### Main and sub-metering for EV charging poles

#### Full energy analysis capability

This range offers you both CT connection inputs and direct connection capabilities. EM24, EM511 and EM330 can be provided also with MID (Measuring Instruments Directive 2014/32/UE) approval for fiscal metering (only for the European market). The three key features of this offer are: housing compactness – they can fit wherever you have a minimal space – most important variable information available at a glance; full electric variables set availability also through the communication port – capability to know the single EV charging pole behaviour so to perform a concise analysis. In addition, EM511 provides, based on Carlo Gavazzi's long design and application expertise, the best meter configuration and installation experience.

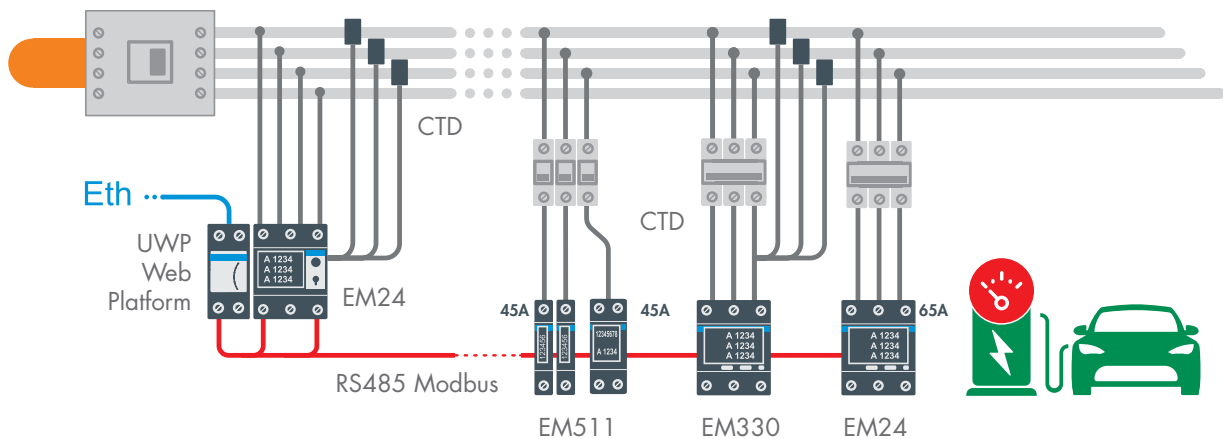

#### EM24 AV5, EM24 E1

##### EM24 AV5

- 4-DIN modules housing
- 3 counter digital inputs
- 2\*8-digit LCD
- Single and three-phase measurements: V, A, Hz, PF, W, VA, var, run-hour, kvarh, 4-tariff, 3\*1-phase kWh
- Basic accuracy (V/A):  $\pm 0.5\%$  RDG, kWh class 1 (IEC62053-21) EM24 AV5
- CT 5 A, up to 600 V L-L ac measuring inputs, 277 V ac power supply
- Pulse output or RS485 Modbus RTU

##### EM24 E1

- CT 5 A, 480 V L-L ac (also wilde leg 120/208/240 V L-L) measuring inputs, 208 V ac power supply
- 65 A, 480 V L-L ac (also wilde leg 120/208/240 V L-L) measuring inputs, self-power supply (208 V ac)

#### EM511

- 45 A, 120V ac measuring inputs
- 1-DIN module housing
- Self-power supply
- 6-digit + 3 decimals backlit LCD
- Measurements: V, A, Hz, PF, W, VA, var, run-hour, kvarh, dual tariff
- V THD and A THD up to 15th harmonics
- Basic accuracy (V/A):  $\pm 0.5\%$  RDG, kWh class 1 (IEC62053-21)
- Bi-directional kWh cl. B EN50470-3 MID approved
- Digital input for tariff management and partial meter: start/pause/reset
- Pulse output or RS485 Modbus RTU

#### EM330

- CT 5 A, 208/480 V L-L ac measuring inputs
- 90V to 260 V ac/dc auxiliary power supply
- 3-DIN modules housing
- Backlit touch 3\*8-digit LCD
- Single and three-phase measurements: V, A, Hz, PF, W, VA, var, run-hour, kvarh, dual tariff, 3\*1-phase kWh
- Basic accuracy (V/A):  $\pm 0.5\%$  RDG, kWh class 1 (IEC62053-21)
- Bi-directional kWh cl. B EN50470-3
- MID approved
- Pulse output or RS485 Modbus RTU



# DC metering solutions for fast EV charging poles

**An innovative solution to drastically reduce both configuration and commissioning time!**

The manufactures of fast, ultra fast and hyper fast chargers for BEVs need a DC meter capable to measure correctly the amount of energy provided to the battery and transmit data to the controller in a secure way, in order to correctly bill the user. In a high power (up to hundreds of kilowatts) charging pole, an AC meter, because of its nature and its installation, provides on the energy totalizer to the user, both losses given by the AC/DC conversion and losses in the cable. This is one of the reasons to adopt a DC meter which would provide, instead, the real net charged energy to the BEV. The Carlo Gavazzi innovative DC meter is called DCT1 and is compatible with most of DC chargers on the market thanks to the wide voltage and current measuring range. The transducer embeds not only many advanced functions such as cable loss compensation but also an easy to mount solution compatible with both bus-bars and cables.

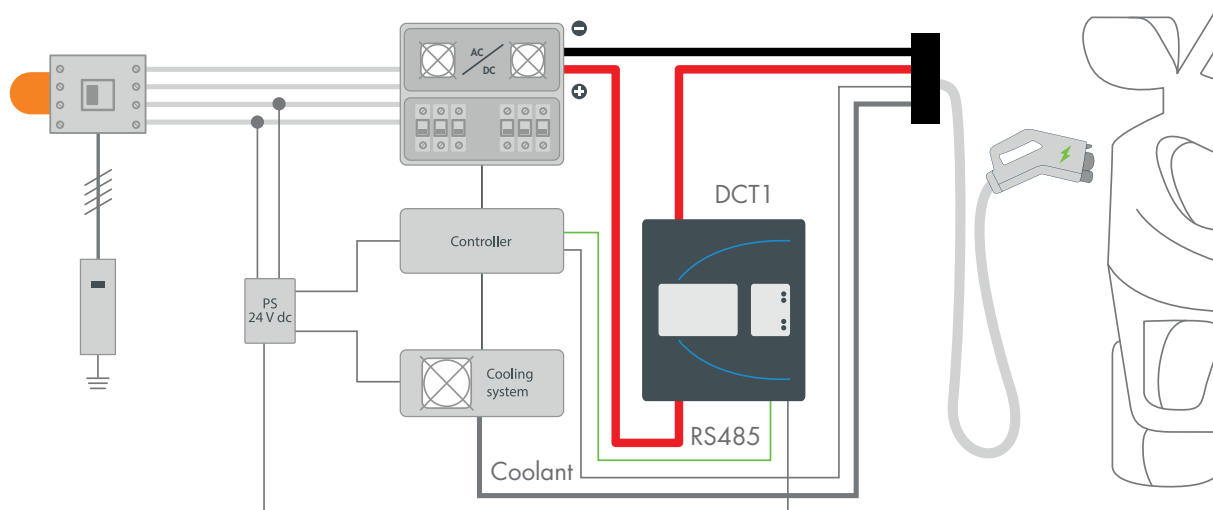

## DCT1

- Current inputs: direct connection up to 600 A (DCT1A60) or up to 300 A (DCT1A30)
- Voltage inputs: 150 to 1000 V dc
- Energy measurements: kWh, total imported and exported, partial imported and exported
- Energy accuracy: cl. 1 (IEC 62053-41) or class B according to VDE-AR-E 2418-3-100 Annex A
- Energy resolution: 0.0001 kWh (0.1Wh)
- Instantaneous and real time variables: V, A, W
- Instantaneous variables accuracy:  $\pm 0.5$  RDG (current/voltage)
- Other variables: Ah ampere-hour meters (total imported and exported, partial imported and exported). Run hour meters (relevant to both imported/exported energy, total and partial). Operating time (total/partial)
- Communication protocol: RS485 Modbus RTU (S1 without signature, S2 with 256 bit signature, S3 with 384 bit signature) or SML (384 bit signature)
- Communication data refresh time: 200 ms
- Others: NMI evaluation certificate for Eichrecht approval according to IEC 62052-11, IEC 62052-31, IEC 62053-41, VDE-AR-E 2418-3-100 Annex A, WELMEC 7.2
- Dimensions: 3.62\*4.53\*2.28 inches (92 x 115 x 58 mm)
- Installation: DIN rail and back panel by screw terminals
- cURus approval

## Innovation and advanced functions

- Cable loss management with cable resistance parameter to calculate only energy provided to the battery, removing losses in the cable
- Real time shunt temperature monitoring via serial communication without additional sensors
- Compatibility with both busbars and cable lugs, vertical, horizontal or mixed connection
- Sealable measuring inputs and communication port, secure data transmission
- Overtemperature, overcurrent or overvoltage warning LEDs and via serial communication









## OUR SALES NETWORK IN EUROPE

### AUSTRIA

Carlo Gavazzi GmbH  
Ketzerergasse 374,  
A-1230 Wien  
Tel: +43 1 888 4112  
Fax: +43 1 889 1053  
office@carlogavazzi.at

### BELGIUM

Carlo Gavazzi NV/SA  
Mechelsesteenweg 311,  
B-1800 Vilvoorde  
Tel: +32 2 257 41 20  
sales@carlogavazzi.be

### DENMARK

Carlo Gavazzi Handel A/S  
Over Hadstenvej 40,  
DK-8370 Hadsten  
Tel: +45 89 60 61 00  
Fax: +45 86 98 15 30  
handel@gavazzi.dk

### FINLAND

Carlo Gavazzi OY AB  
Ahventie, 4 B  
FI-02170 Espoo  
Tel: +358 9 756 2000  
myynti@gavazzi.fi

### FRANCE

Carlo Gavazzi Sarl  
Zac de Paris Nord II, 69, rue de la Belle Etoile,  
F-95956 Roissy CDG Cedex  
Tel: +33 1 49 38 98 60  
Fax: +33 1 48 63 27 43  
french.team@carlogavazzi.fr

### GERMANY

Carlo Gavazzi GmbH  
Pfnorstr. 10-14  
D-64293 Darmstadt  
Tel: +49 6151 81 00 0  
Fax: +49 6151 81 00 40  
info@gavazzi.de

### GREAT BRITAIN

Carlo Gavazzi UK Ltd  
4.4 Frimley Business Park,  
Frimley, Camberley, Surrey GU16 7SG  
Tel: +44 1 276 854110  
Fax: +44 1 276 682140  
sales@carlogavazzi.co.uk

### ITALY

Carlo Gavazzi SpA  
Via Milano, 13,  
I-20045 Lainate  
Tel: +39 02 931 76 1  
Fax: +39 02 931 76 301  
info@gavazziacbu.it

### NETHERLANDS

Carlo Gavazzi BV  
Wijkermeerweg 23,  
NL-1948 NT Beverwijk  
Tel: +31 251 22 93 45  
Fax: +31 251 22 60 55  
info@carlogavazzi.nl

### NORWAY

Carlo Gavazzi AS  
Melkeveien 13,  
N-3919 Porsgrunn  
Tel: +47 35 93 08 00  
Fax: +47 35 93 08 01  
posti@gavazzi.no

### PORTUGAL

Carlo Gavazzi Lda  
Rua dos Jerónimos 38-B,  
P-1400-212 Lisboa  
Tel: +351 21 361 70 60  
Fax: +351 21 362 13 73  
carlogavazzi@carlogavazzi.pt

### SPAIN

Carlo Gavazzi SA  
Avda. Iparraguirre, 80-82,  
E-48940 Leioa (Bizkaia)  
Tel: +34 94 480 40 37  
Fax: +34 94 431 60 81  
gavazzi@gavazzi.es

### SWEDEN

Carlo Gavazzi AB  
V:a Kyrkogatan 1,  
S-652 24 Karlstad  
Tel: +46 54 85 11 25  
Fax: +46 54 85 11 77  
info@carlogavazzi.se

### SWITZERLAND

Carlo Gavazzi AG  
Verkauf Schweiz/Vente Suisse  
Sumpfstrasse 3,  
CH-6312 Steinhausen  
Tel: +41 41 747 45 35  
Fax: +41 41 740 45 40  
info@carlogavazzi.ch

## OUR SALES NETWORK IN THE AMERICAS

### USA

Carlo Gavazzi Inc.  
750 Hastings Lane,  
Buffalo Grove, IL 60089-6904, USA  
Tel: +1 847 465 61 00  
Fax: +1 847 465 73 73  
sales@carlogavazzi.com

### CANADA

Carlo Gavazzi Inc.  
2430 Meadowpine Blvd Unit 104  
Mississauga, ON L5N 6S2,  
Canada  
Tel: +1 905 542 0979  
gavazzi@carlogavazzi.com

### MEXICO

Carlo Gavazzi Mexico S.A. de C.V.  
Circuito Puericultores 22, Ciudad Satelite  
Naucalpan de Juárez, Edo Mex. CP 53100  
Mexico  
T +52 55 5373 7042  
F +52 55 5373 7042  
mexicosales@carlogavazzi.com

### BRAZIL

Carlo Gavazzi Automação Ltda.  
Av. Francisco Matarazzo, 1752  
Conj 2108 05001-200 - São Paulo - SP  
Tel: +55 11 3052 0832  
Fax: +55 11 3057 1753  
info@carlogavazzi.com.br

## OUR SALES NETWORK IN ASIA AND PACIFIC

### SINGAPORE

Carlo Gavazzi Automation Singapore Pte. Ltd.  
61 Tai Seng Avenue #05-06  
Print Media Hub @ Paya Lebar iPark  
Singapore 534167  
Tel: +65 67 466 990  
Fax: +65 67 461 980  
info@carlogavazzi.com.sg

### MALAYSIA

Carlo Gavazzi Automation (M) SDN. BHD.  
D12-06-G, Block D12,  
Pusat Perdagangan Dana 1,  
Jalan PJU 1A/46, 47301 - Petaling Jaya,  
Selangor, Malaysia  
Tel: +60 3 7842 7299  
Fax: +60 3 7842 7399  
info@gavazzi-asia.com

### CHINA

Carlo Gavazzi Automation  
(China) Co. Ltd.  
Unit 2308, 23/F.,  
News Building, Block 1, 1002  
Middle Shennan Zhong Road, Futian District,  
Shenzhen, China  
Tel: +86 755 8369 9500  
Fax: +86 755 8369 9300  
sales@carlogavazzi.cn

### HONG KONG

Carlo Gavazzi Automation  
Hong Kong Ltd.  
Unit No. 16 on 25<sup>th</sup> Floor, One Midtown,  
No. 11 Hoi Shing Road, Tsuen Wan,  
New Territories, Hong Kong  
Tel: +852 26261332 / 26261333  
Fax: +852 26261316

### TAIWAN

Branch of Carlo Gavazzi Automation  
Singapore Pte. Ltd.  
22F-1, No.500 Shizheng Rd, Xitun Dist,  
Taichung City 407,  
Taiwan, China  
Tel: +886 4 2258 4001  
Fax: +886 4 2258 4002

## OUR COMPETENCE CENTRES AND PRODUCTION SITES

### DENMARK

Carlo Gavazzi Industri A/S  
Hadsten

### MALTA

Carlo Gavazzi Ltd  
Zejtun

### ITALY

Carlo Gavazzi Controls SpA  
Belluno

### LITHUANIA

Uab Carlo Gavazzi Industri Kaunas  
Kaunas

### CHINA

Carlo Gavazzi Automation (Kunshan) Co., Ltd.  
Kunshan

## HEADQUARTERS

Carlo Gavazzi Automation SpA  
Via Milano, 13  
I-20045 - Lainate (MI) - ITALY  
Tel: +39 02 931 76 1  
info@gavazziautomation.com

*Energy to Components!*

www.gavazziautomation.com